



**ROHDE & SCHWARZ
MÜNCHEN**

Instruction Book

**AMF-FM SIGNAL GENERATOR
SMDA**

100.4559.04

Table of Contents

1.	General	
1.1	Uses	95
1.2	Deskription	96
1.3	Specifications	97
1.4	Accessories Supplied	101
1.5	Recommended Extras	101
1.5.1	Specifications of Signal Generator with Frequenzkontroller 100.4542	102
1.5.2	Specifications of Signal Generator with Power Test Adapter 100.4620	103
1.5.3	Coupling Head 124.7558.50	104
1.5.4	Fixing Kit 082.5476.02	105
2.	Preparation for Use and Operation	
2.1	Table of Controls	107
2.2	Adjusting to the Local AC Supply Voltage	111
2.3	Adjusting the Zero of the Meter	112
2.4	Frequency Setting	112
2.4.1	Adjusting the Frequency of the RF Oscillator	112
2.4.2	Calibration of the Frequency Scale	112
2.4.3	Incremental Tuning	112
2.5	Output Voltage Adjustment	113
2.5.1	Setting the RF Output Voltage and Taking the Reading	113
2.5.2	Connecting the Load	113
2.5.3	Voltage at the Load	114
2.5.4	Power Consumption of the Load	114
2.5.5	Adjusting Extremely Small Output Voltages	115
2.5.6	Adapting the RF Output 16 to Other Connector Systems	116
2.6	Modulation Generator	116
2.6.1	Frequency Setting	116
2.6.2	Voltage Setting	116
2.7	Types of Modulation	117
2.7.1	Frequency Modulation	117
2.7.2	Phase Modulation	117
2.7.3	Amplitude Modulation	118
2.8	Frequency Deviation Measurement with Frequenzkontroller BN 413115	118
3.	Maintenance and Repair	
3.1	Measuring Instruments and Auxiliary Equipment Required	119
3.2	Performance Check	121
3.2.1	RF Output	121
3.2.1.1	Frequency	121
3.2.1.2	Checking the Output Voltage or Output Power	121
3.2.1.3	Measuring the Non-harmonic Spurious Waves	122
3.2.1.4	Measuring the Harmonics	122
3.2.1.5	Measuring the Residual FM	122
3.2.1.6	Measuring the Noise Voltage	123
3.2.2	Modulation Generator	125
3.2.2.1	Measuring the Frequency	125
3.2.2.2	Measuring the Output Voltage	125
3.2.2.3	Checking the Output-voltage Indication	125

3.2.2.4	Measuring the AF Distortion Factor	126
3.2.3	Modulation	126
3.2.3.1	Checking the Internal Amplitude Modulation	126
3.2.3.2	Checking the External Amplitude Modulation	127
3.2.3.3	Measuring the Spurious AM with Frequency Modulation	128
3.2.3.4	Measuring the Modulation Distortion with AM	128
3.2.3.5	Checking the Internal Frequency Modulation	129
3.2.3.6	Checking the External Frequency Modulation	130
3.2.3.7	Measuring the Modulation Distortion with FM	130
3.2.3.8	Checking the Phase Modulation	131
3.2.3.9	Checking the Level Adjustment Frequency of the Phase Modulation	131
3.2.3.10	Checking the AF Response with Phase Modulation	131
3.2.3.11	Measuring the Modulation Distortion with φM	131
3.2.3.12	Checking the Response Threshold of the Maximum Frequency Deviation Indication	131
3.2.3.13	Checking the Automatic IF Generation	132
3.2.4	Measuring the Voltage at RF Output II	132
3.2.5	Measuring the AF Distortion Factor	132
3.2.6	Measuring the Frequency Deviation in Sweep Operation	132
3.2.7	Measuring the RF Leakage	133
3.2.7.1	Determination of the Receiver Sensitivity	133
3.2.7.2	Measuring the RF Leakage	133
3.2.8	Checking the Output Voltage on the VOR-ILS Unit	134
3.3	Mechanical Maintenance	134
3.3.1	Cleaning	134
3.3.2	Withdrawing the Chassis from the Cabinet	135
4.	Circuit Description	
4.1	Oscillator and Frequency Modulator	137
4.2	FM Chokes	137
4.3	Deviation Network	137
4.4	Buffer	137
4.5	AGC Circuit	137
4.6	Frequency Converter	138
4.7	Low-pass Filter Preceding the Mixer	138
4.8	Mixer	138
4.9	Low-pass Filter Following the Mixer	138
4.10	Crystal Stage	138
4.11	Second-output Amplifier	138
4.12	Modulator	139
4.13	Output Stage and Output Filter	139
4.14	Attenuator	139
4.15	Overload Protector	139
4.16	AGC Amplifier	140
4.17	Modulation Unit	140
4.18	Power Supply	141
4.19	Mechanical Construction	142
4.19.1	Removing the Operating Controls	142
4.19.2	Withdrawing the Modulation Unit	142
4.19.3	Opening the Oscillator and Replacing the Oscillator Segments	142
4.19.4	Withdrawing the RF Attenuator and the AGC Amplifier	143
4.19.5	Withdrawing the Overload Protector	143
4.19.6	Withdrawing the Power Supply	143

4.19.7	Withdrawing the Crystal Stage	144
4.19.8	Withdrawing the FM Chokes	144
4.19.9	Withdrawing the Pushbutton Assembly and the Deviation Network	144
4.19.10	Withdrawing the Amplifier	144
4.19.11	Withdrawing the Buffer, AGC Circuit, Mixer, Modulator, Output Stage	144
5.	Repair Instructions	
5.1	Measuring Instruments and Auxiliary Equipment Required	145
5.2	Trouble-shooting	147
5.2.1	Power Supply	147
5.2.2	RF Voltage	147
5.2.3	Modulation Unit	148
5.3	Performance Check of Subassemblies	148
5.3.1	Power Supply	148
5.3.2	Oscillator	149
5.3.3	FM Chokes and Operating-voltage Leads	151
5.3.4	Buffer and AGC	151
5.3.5	Mixer	152
5.3.6	Crystal Stage	153
5.3.7	Second-output Amplifier	153
5.3.8	Buffer and Modulator	154
5.3.9	Output Stage	154
5.3.10	Filter	155
5.3.11	Attenuator	155
5.3.12	AGC Amplifier	156
5.3.13	Overload Protector	158
5.3.14	Modulation Generator (in the Modulation Unit)	159
5.3.15	Meter Amplifier (in the Modulation Unit)	159
5.3.16	Deviation Network	159
5.3.17	Connectors for the Frequenzkontroller	160
5.4	Trimming Instructions	160
5.4.1	Power Supply	160
5.4.2	Oscillator	160
5.4.3	Frequency Modulation	164
5.4.4	AGC Amplifier	164
5.4.5	Modulator	165
5.4.6	Crystal Stage	165
5.4.7	Overload Protector	165
5.4.8	Modulation Generator	166
5.4.9	Meter Amplifier	166
5.4.10	Automatic IF Generation	167
5.4.11	Mixer	167
5.5	Calibration of the Subassemblies	167
5.5.1	Oscillator: Zero Beat in Frequency Range I	167
5.5.2	Attenuator	167
5.5.3	Calibrating the Fine Tuning of the Modulation Frequency	169

Appendix

Fig. 1-2	Block diagram	171
Fig. 2-1	Front panel	173
Fig. 2-2	Rear panel	173
Fig. 4-1	Bottom view, cabinet removed	175
Fig. 4-2	Top view, modulation generator with drawn	177
Fig. 4-3	Top view, cabinet removed	179
Fig. 4-4	Rear view, cabinet removed	179
Fig. 4-5	Left-hand side view, cabinet removed	181
Fig. 4-6	Right-hand side view, cabinet removed	181
Fig. 4-7	Oscillator	183
Fig. 5-16	Level diagram	185
Table 18	List of subassemblies and component parts	187
Circuitry documentation	(see separate index)	189

1. General

1.1 Uses

The AM-FM Signal Generator Type SMDA 100.4559 is particularly suitable for measurements on receivers. All IF measurements can be performed thanks to the high output voltage and the low frequency limit at which the modulation characteristics are as good as in the upper frequency ranges. High frequency stability allows measurements to be taken on receivers with narrow channel spacing. The incremental tuning control calibrated in kHz is of advantage in measurements of adjacent-channel selectivity, intermodulation and cross-modulation, whereas the high scale resolution is sufficient for other selectivity measurements. Low RF leakage and an output attenuator adjustable down to $0.1 \mu\text{V}$ permit accurate S/N ratio and sensitivity measurements. Simultaneous AM and FM is ideal for measurements on limiters. The twelve fixed frequencies provided, which, in addition, may be finely adjusted over a range from -30 to $+400$ Hz, are very useful in modulation measurements, and the low distortion is important at high percentage modulation.

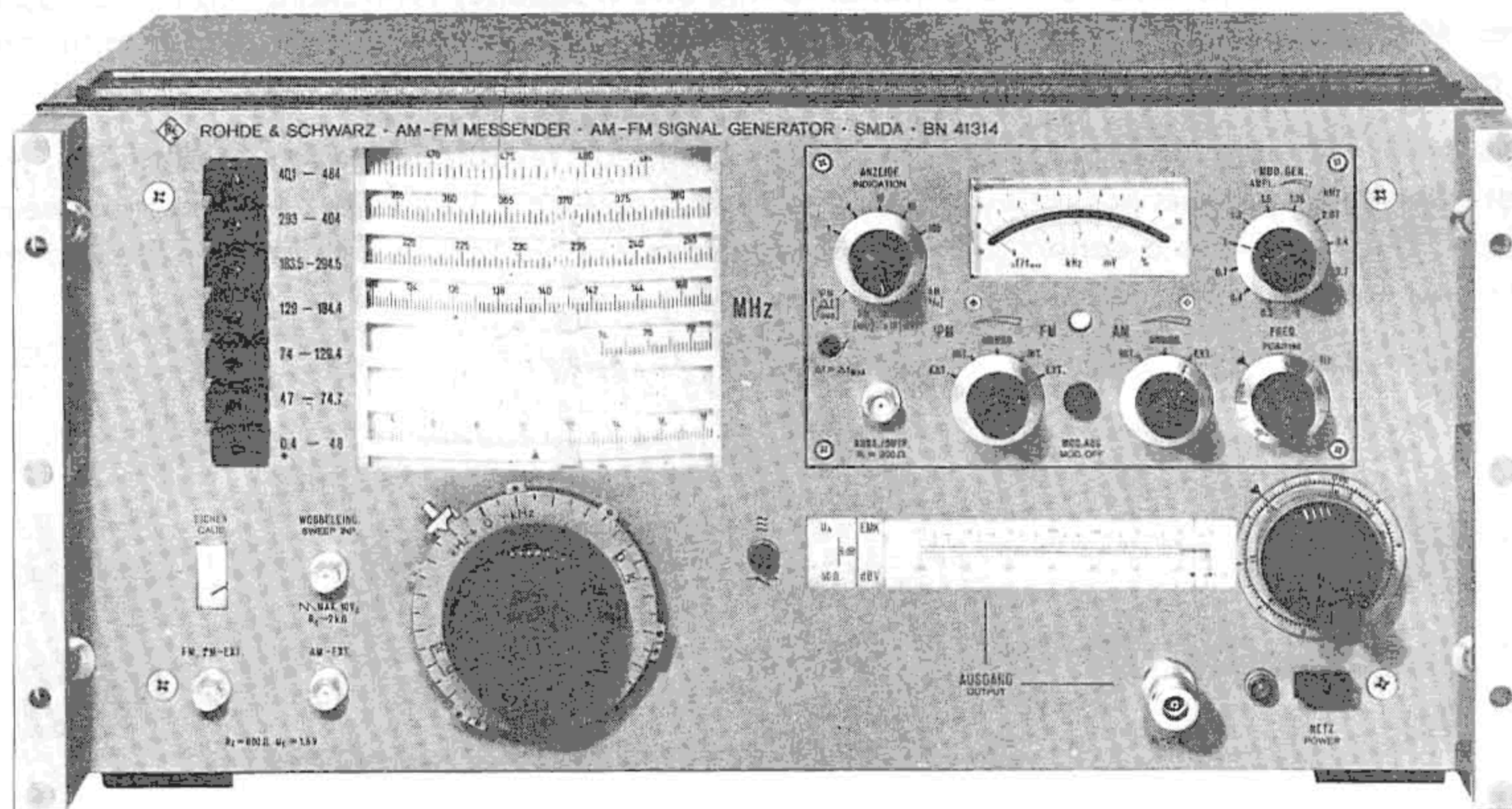

Fig. 1-1 AM-FM Signal Generator Type SMDA 100.4559

The modulation generator is provided with an output socket for measurements on the AF section of a receiver. The output voltage is continuously adjustable and can be read on the modulation meter in five switch-selected ranges.

The high output voltage, flat frequency response and low harmonic content of the SMDA are particularly useful in measurements on broad-band test items, such as amplifiers, filters mixers and transformers.

Mobile use is facilitated by small dimensions, light weight, the possibility of battery operation, small power consumption and negligible transient response.

When during the checking of a transmitter-receiver the push-to-talk button is pressed by mistake, the AM-FM Signal Generator Type SMDA is not destroyed – as other signal generators may be – since an RF overload protection is provided for the output attenuator and output stage.

Whenever the output frequency of the SMDA must be known to within 100 Hz (or 10 Hz for 1 sec measuring time) or when a frequency stability of 2×10^{-7} is required, for example in unattended long-term measurements, the signal-generator frequency can be accurately measured and synchronized with the Frequenzkontroller 100.4542. This unit can be placed on the signal generator, connected to it at the rear via a cable, and switched on together with the signal generator. The frequency is then indicated in seven digits by indicator tubes. The SMDA can be frequency modulated even if synchronized.

1.2 Description (Fig. 1-2)

The SMDA is fully transistorized. In the range 47 to 484 MHz, its high-stability **oscillator** operates directly at the output frequency, thus ensuring complete freedom from non-harmonic spurious frequencies. Careful design of the oscillator makes for high spectral purity, i. e. prevents noise pickup in the adjacent channel. **Tuning** is continuous throughout the range, permitting rapid frequency selection. Each range on the frequency scale can be calibrated individually, the **Incremental tuning** being calibrated in kHz.

In the range 0.4 to 48 MHz, the output signal is obtained by the beat method, ensuring the same favourable conditions for incremental tuning and frequency modulation as in the upper ranges. **Modulation depth, frequency or phase deviation and AF output voltage** are indicated on a panel meter with mirror scale.

Buffers with ALC minimize amplitude response, oscillator reradiation and residual FM. An **output attenuator** permits the adjustment of voltages between 0.1 μ V and 1 V EMF or between -140 and 0 dB (V_{EMF}) on a calibrated scale. Outputs for connection of the Frequenzkontroller, Power Test Adapter and VOR-ILS Unit are provided on the rear.

1.3 Specifications

Frequency

Range	Subranges	Scale resolution (mm)
	0.4 to 48 MHz	130 kHz
	47 to 74.7 MHz	65 kHz
	74 to 129.5 MHz	130 kHz
	129 to 184.5 MHz	130 kHz
	183.5 to 294.5 MHz	260 kHz
	293 to 404 MHz	200 kHz
	401 to 484 MHz	195 kHz
Error limits	$\pm 0.5\%$	
from 0.4 to 48 MHz	$\pm (1.5\% + 100 \text{ kHz})$ with incorporated calibration facility	
Incremental tuning	calibrated in kHz	
Error limits	$\pm (8\% \pm 2 \text{ kHz})^1)$	
Expansion with respect to main scale . . .	130 which corresponds to $< 2 \text{ kHz/mm}$	
Frequency variation after 10 min warm-up time or after changing the frequency ²⁾		
in the range 0.4 to 185 MHz	$< \pm 1.5 \text{ kHz/5 min}$	
over the remainder of the range	$< 10^{-5}/5 \text{ min, typ. } \pm 2.5 \text{ kHz/5 min}$	
Frequency variation after 3 hours operation, or 15 min after changing the frequency ²⁾		
in the range 0.4 to 185 MHz	$< \pm 600 \text{ Hz/10 min}$	
over the remainder of the range	$< 6 \times 10^{-6}/10 \text{ min, typ. } 4 \cdot 10^{-6}$	
Synchronization via 2nd RF output	crystal-controlled by Frequenzkontroller 100.4542	
Residual FM	$< 10 \text{ Hz}$ (weighted with CCIF filter 0.3 to 3 kHz)	

S/N ratio for 1-Hz test bandwidth

	at $\cong 20 \text{ kHz}$	at $\cong 100 \text{ kHz}$
0.4...48 MHz	$> 125 \text{ dB}$ (typ. 135 dB)	
47...48 MHz	$> 130 \text{ dB}$ (typ. 140 dB)	$> 135 \text{ dB}$ (typ. 145 dB)
184...404 MHz	$> 125 \text{ dB}$ (typ. 135 dB)	
404...484 MHz	$> 120 \text{ dB}$ (typ. 130 dB)	

¹⁾ Approx. 15 % from 401-420 MHz and from 470-484 MHz.
²⁾ at a constant ambient temperature

RF harmonic suppression

50 to 484 MHz	> 30 dB	} at levels below 200 mV _{EMF}
0.4 to 50 MHz	> 26 dB, typical value 30 dB	

Suppression of non-harmonic spurious

responses	no spurious responses
from 0.4 to 35 MHz	> 70 dB
from 35 to 48 MHz	> 50 dB

RF output

Output impedance	50 Ω , VSWR < 1.3, typical value 1.2 at output levels < -20 dB V _{EMF} (with Dezifix A connector only)
Output EMF	1 V corresponding to 0 dBV _{EMF} , (continuously adjustable between 0.1 μ V and 1 V or -140 dBV _{EMF} and +0 dBV _{EMF})
Indication of output voltage	on linear scale in dBV and V _{EMF} E _{out} into 50 Ω
Minimum output voltage variation	0.25 dB
Scale resolution	0.7 mm/dB or 16 mm/dB (fine-adjustment scale)
Error limits of indication	< ± 1 dB at output levels < 10 dBV _{EMF}
RF output II (rear)	N socket (supplied with other connectors on request)
Output voltage	15 to 75 mV into 50 Ω
Output impedance	approx. 50 Ω

Modulation

Types	AM, FM, φ M or AM + FM or AM + φ M
-----------------	----------------------------------------------------

Frequency modulation

Types	internal and external
Frequency deviation	0 to 75 kHz, adjustable (if the maximum deviation is exceeded, a red lamp lights up)

Modulation frequency

internal	with modulation generator
external	30 Hz to 20 kHz

Modulation distortion

with frequency deviation ≤ 4 kHz	< 1 %
with frequency deviation ≤ 25 kHz	< 5 %
with frequency deviation ≤ 75 kHz	< 10 %

External modulation

Voltage requirement for maximum frequency deviation	approx. 2.5 V
Input impedance	600 Ω
Input	BNC socket

Frequency deviation indication	on meter
Ranges	1/4/10/40/100 kHz
Error limits up to 25 kHz frequency deviation	$\pm(5\% + 1.5\% \text{ of FS})$ ¹⁾
Incidental AM with 10 kHz frequency deviation	$< 1\%$
Sweeping	via BNC socket on the front panel
Sweep width	depending on frequency range, max. $\pm(75 \text{ to } 300)$ kHz
Sweep frequency	0 to 1 kHz
Voltage requirement	frequency-dependent, ± 10 V into 1.5 k Ω , max. (max. ± 20 V into > 5 k Ω at 0.4–48 MHz)
Phase modulation	
Types	internal and external
Modulation index	adjustable from 0 to 100
Frequency deviation	75 kHz, max., depending on the modulation frequency (if exceeded, red lamp lights up)
Level adjustment frequency	1 kHz $\pm 3\%$ (same frequency deviation for φ M and FM)
Modulation frequency	
internal	from built-in modulation generator
external	30 Hz – 10 kHz
Modulation distortion	
with frequency deviation ≤ 4 kHz	$< 1\%$ ($< 5\%$ with deviation < 25 kHz, $< 10\%$ with deviation < 75 kHz)
External modulation	
Voltage requirement	approx. 2.5 V into 600 Ω for maximum frequency deviation; input: BNC socket
Indication of modulation index or frequency deviation	
	on panel meter
Indicating ranges	1/4/10/40/100 $\Delta f/f_{\text{mod}}$ or kHz, resp.
Error limits of modulation index $\Delta f/f_{\text{mod}}$ up to 25 kHz frequency deviation	$\pm(5\% + 1.5\% \text{ of FS})$ ¹⁾ typical value 2%
Incidental AM at 10 kHz frequency deviation	$< 1\%$
Max. permissible departure from the frequency-proportional deviation characteristic	
up to $f_{\text{mod}} = 3$ kHz	$< 3\%$
up to $f_{\text{mod}} = 5$ kHz	$< 6\%$
up to $f_{\text{mod}} = 10$ kHz	$< 30\%$

¹⁾ Approx. 10% from 401–420 MHz and from 470–484 MHz.

Amplitude modulation

Types	internal and external
Modulation depth	95 % max.
Frequency range	
internal	with modulation generator
external	30 Hz to 10 kHz
Modulation distortion	
at 80 % mod. 30 Hz to 4 kHz	< 2.5 % typical value 1 %
External modulation	
Voltage requirement for 95 % mod.	approx. 1.2 V
Input impedance	approx. 600 Ω
Input	BNC socket
Modulation depth indication	on meter
Ranges	(1/4)/10/40/100 % ¹⁾
Error limits up to 90 % mod.	$\pm(3\% + 1.5\% \text{ of FS})$ at output levels < 10 dBV _{EMF}
Residual AM	< 0.1 % (weighted with CCIF filter 0.3 to 3 kHz)
Incidental FM at 30 % AM and < 0.1 kHz modulation frequency	< 30 Hz

Built-in modulation generator

Fixed frequencies	0.3/0.4/0.7/1/1.3/1.5/1.75/2.07/ 2.4/2.7/3/6 kHz
Error limits	$\pm 1.5\%$
Fine tuning of fixed frequencies	- 30 to + 400 Hz
Error limits	$\pm(5\% + 5 \text{ Hz})$
Output voltage indication	< 0,5 mV to 1 V
Minimum load impedance	200 Ω
Input impedance	approx. 200 Ω
Distortion	< 0.5 %
Output voltage indication	on meter
Ranges	10/40/100/400/1000 mV
Error limits	$\pm(4\% + 1.5\% \text{ of FS})$
Output	BNC socket

RF overload protection responds automatically when RF power is applied to the output

Max. permissible RF power	20 W
Reset	automatic
Indication	by pilot lamp
Test output for VOR-ILS Unit	
Rectified voltage	approx. - 3.5 V
AF voltage at 40 % AM	0.99 V

¹⁾ The indicating ranges 1 and 4 % are for checking purposes only; indicated values not guaranteed.

General data

AC supply	115/125/220/235 V \pm 10 % 47 to 440 Hz; 18 VA
Battery operation	two batteries 22 to 26 V/500 mA or 120 mA can be connected at the rear
Ambient temperature	
Operating temperature	10 °C to 45 °C
Shelf temperature	- 45 °C to + 60 °C
Dimensions (W x H x D) (with cover)	484 x 238 x 338 mm
Weight	17 kg

Diodes, transistors, etc.

1 germanium diode AAY 10/120	1 relay in BN 41311-7.1.1
6 silicon varactors BB 105 B	1 fuse M 0,1 C DIN 41571 for 220 V or M 0,2 C DIN 41571 for 115 V
2 bridge-connected rectifiers B 60 C 600 Si	1 silicon transistor BC 214
2 silicon diodes HPA 3080	13 silicon transistors BC 171 B
4 silicon diodes HPA 5082-2800	2 silicon transistors BC 251 B
1 meter diode HFA 5082-4440	12 silicon transistors BCY 59 IX
1 silicon diode 1 N 4002	7 silicon transistors BCY 79 IX
2 silicon diodes 2 N 936	2 silicon transistors BF 223
26 silicon diodes 1 N 914	2 silicon transistors BF 244 A
2 silicon Zener diodes ZD 4,7	5 silicon transistors BFR 15
2 silicon Zener diodes ZF 3,9	2 silicon transistors BFR 35
3 silicon Zener diodes ZF 5,6	1 silicon transistor BFW 16
2 silicon Zener diodes ZF 18	1 silicon transistor BFW 30
2 Zener diodes ZP 3.5	3 silicon transistors BFY 90
1 Zener diode ZP 5.6	2 silicon transistors BSV 81
1 Zener diode ZP 6.8	2 silicon transistors BSY 55
1 Zener diode ZP 8.2	1 silicon transistor MD 007
1 Zener diode ZP 10	1 silicon transistor 2 N 2914
1 Zener diode ZP 12	6 silicon transistors 2 N 4416
1 Zener diode ZP 15	2 silicon transistors 2 N 5296
3 silicon diodes 12 P 2	1 silicon transistor TIP 32
1 crystal RN 3 K 1 A DIN 45111 (129 MHz)	2 operational amplifier μ A 709 C
1 glow lamp EG 019.2750	1 operational amplifier μ A 715
1 incandescent lamp EF 019.2650	1 buffer amplifier SG 310
4 relay coils BN 41311-5.11.5	4 operational amplifier μ A 714
10 relay coils BN 41311-5.22.5	

1.4 Accessories Supplied

- 1 Power Cable 025.2365.00
- 1 Coupling Connector FO 018.5356

1.5 Recommended Extras

- 1 RF Patch Cord 100.6945.10 (for modulation input, BNC connector)
- 1 RF Patch Cord 100.7670.10 (50 Ω , N connector)

- 1 Frequenzkontroller 100.4542
(crystal control unit with 7-digit frequency counter; section 1.5.1)
- 1 Counter Adapter 100.8131.02
- 1 Power Test Adapter 100.4620 (RF switch, attenuator pad and power meter; connector for radiotelephone systems; section 1.5.2)
- 1 Vor-ILS Unit 214.3115.02
- 1 Fixing Kit (section 1.5.4)
- 1 Coupling Head 124.7558.50 (section 1.5.3)
- 1 Polyskop Type SWOB III consisting of:
 - Basic Unit with Display Unit (100.5249 + 100.5349)
 - Deflection Amplifier Lin-Log 100.5390
 - Voltage Reference Lines Plug-in 100.5403
 - Time-Base Plug-in 100.8054

1.5.1 Specifications of Signal Generator with Frequenzkontroller 100.4542

Frequency range	0.4 to 484 MHz	
Frequency indication		
Accuracy	10 Hz and 100 Hz, respectively	
Temperature coefficient	$< 2 \times 10^{-8}/^{\circ}\text{C}$	
Aging	$< 5 \times 10^{-8}/\text{month}$	
Frequency instability	$< 2 \times 10^{-7}/\text{h}^1)$	} in the lower range
	$< 2 \times 10^{-7}/^{\circ}\text{C}$	
	$< 2 \times 10^{-6}/\text{h}^1)$	
	$< 2 \times 10^{-6}/^{\circ}\text{C}$	
Electronic fine tuning	1 % in the lower range 0.1 % in all other ranges	
Spacing of locked frequencies in the tuning range	5/20/40/80 kHz, depending on frequency range	
Frequency modulation		
Permissible modulation index	< 20	
Permissible modulation frequency	> 100 Hz	

Frequency counter

Frequency range switching	ganged with signal-generator range		
Readout	7 digits		
Resolution	100 Hz at 0.1 sec gate time	} in position FREQ. INT. + EXT. B	
	10 Hz at 1 sec gate time		
	10 Hz at 0.1 sec gate time		} in position FREQ. EXT. A
	1 Hz at 1 sec gate time		
Error limits	± 100 Hz, ± 10 Hz and ± 1 Hz, respectively		
Time base	10 MHz, crystal-controlled; external calibration possible		
Error limits of time base			
Temperature effect	$< 2 \times 10^{-8}/^{\circ}\text{C}$		
Aging	$< 5 \times 10^{-8}/\text{month}$		
Warm-up time	< 15 min		

¹⁾ After a warm-up period of 40 min.
During the warm-up period of 15 to 40 min the values $< 2 \times 10^{-7}/15$ min and $< 2 \times 10^{-6}/15$ min, respectively apply.

Deviation measurement (positive and negative deviations can be measured separately)

Frequency deviation

Ranges of indication	5 kHz and 20 kHz
Modulation frequency	50 Hz to 9 kHz
Error limits	$\pm 1.5\%$ of measured value $\pm 1.5\%$ of FS

Phase deviation

Ranges of indication	$\Delta f/f_{\text{mod}} = 2$ and $\Delta f/f_{\text{mod}} = 5$
Error limits	$\pm 2\%$
Modulation frequency	300 Hz to 9 kHz

Relative error between

positive and negative measurement	$\pm 1.5\%$ of FS
---------------------------------------------	-------------------

Voltage requirement	100 mV into 50 Ω
-------------------------------	-------------------------

Check	green pilot lamp lights if level is sufficient and frequency correct
-----------------	----------------------------------------------------------------------

Test output

Output level	14 V _{pp} at f.s.d., or 1 mV _{rms} /Hz
------------------------	----------------------------------------------------------

Output impedance	2 k Ω
----------------------------	--------------

Residual FM or φM	< 15 Hz weighted according to CCIF
--------------------------------------	------------------------------------

Automatic indication of modulation

frequency for deviation measurement	10 Hz at 0.1 sec gate time
-----------------------------------------------	----------------------------

Resolution	1 Hz at 1 sec gate time
----------------------	-------------------------

General data

AF output and front-panel input	BNC sockets
-------------------------------------------	-------------

RF input (50 Ω)	N plug, can be adapted to other connector systems
-----------------------------------	---------------------------------------------------

AC supply	115/125/220/235 V $\pm 10\%$, 47 to 440 Hz, 47 VA
---------------------	----------------------------------------------------

Ambient temperature

Operating temperature	+10 °C to +45 °C
---------------------------------	------------------

Shelf temperature	-40 °C to +60 °C
-----------------------------	------------------

Dimensions (W x H x D)	484 x 91 x 338 mm
----------------------------------	-------------------

Weight	10 kg
------------------	-------

Order designation	Frequenzkontroller 100.4542 for SMDF/SM DA
-----------------------------	--------------------------------------------

1.5.2 Specifications of Signal Generator with Power Test Adapter 100.4620

Frequency range	10 to 500 MHz
---------------------------	---------------

Power ranges	0.01 to 0.2/0.1 to 2/1 to 20 W
------------------------	--------------------------------

Error limits	+6% of measured value $\pm 1.5\%$ of FS
------------------------	-----------------------------------------

VSWR	approx. 1.05
----------------	--------------

Accuracy of the 20-dB/20-W attenuator

(10 to 500 MHz)	± 0.2 dB
---------------------------	--------------

Types of operation selectable on the Power Test Adapter

Receiver	receiver-section measurement on radio-telephone systems
Power	power measurement on transmitter section
Deviation	frequency-deviation measurement on transmitter section
Frequency	frequency measurement on transmitter section
RF inputs or outputs, respectively (50 Ω)	N sockets, can be adapted to other connector systems
AF output	BNC socket
AC supply	115/125/220/235 V ± 10 %; 47 to 440 Hz, 6 VA
Ambient temperature	
Operating temperature	+10 °C to +45 °C
Shelf temperature	-45 °C to +70 °C
Dimensions (W x H x D)	484 x 91 x 338 mm
Weight	7 kg
Order designation	Power Test Adapter 100.4620 for SMDF/SMDA

1.5.3 Coupling Head 124.7558.50

The coupling head consists of a cylindrical casing provided with a grub screw at its front end. A flexible coaxial cable with N connector is used to connect the coupling head to the output of the signal generator. The cable is match-terminated in the probe casing; the RF voltage across the termination is coupled out via an isolating capacitor and taken to the probe tip.

The isolating capacitor has a rating of 47,000 pF ± 20 %, its highest permissible DC loading is 400 V. The termination of the coupling head is single-ended. The characteristic impedance is 50 Ω

The source impedance of the signal generator together with the coupling head, as seen from the test item, is 50 Ω. The coupling head is used to feed the signal-generator voltage to high-impedance points that present a DC potential to chassis.

Test connections:

Three types of probe tips can be screwed to the grub screw at the front end of the probe.

Straight tip	in insulating bushing (approx. 30 mm long), 19129-5
Retractable hook tip	for hooking to connecting leads (spring-loaded in insulating bushing about 80 mm long), 19129-3
Clamping tip	for clamping wires of 0.8 to 1 mm dia., approx. 20 mm long, 19129-6

Chassis connections:

Cable	with alligator clip (approx. 220 mm long), to be attached to the rear end of the probe, 19129-8
Cable	with alligator clip (approx. 120 mm long), to be inserted into clamp 41300-36.7, 19129-7
Clamp	for sliding onto the probe casing with 4-mm hole for insertion of banana plug and wire clamping device (max. wire diameter 1 mm), 41300-36.7

1.5.4 Fixing Kit 082.5476.02

When a test assembly, comprising the AM-FM Signal Generator SMDA, Frequenzkontroller and Power Test Adapter, is set up, the individual instruments can be screwed together with the Fixing Kit 082.5476.02.

If the **sidewalls** of the instrument are **perforated**, hook the blocks 41311-35.1/2 into the four outer perforations in the corners, and join them together with screws provided.

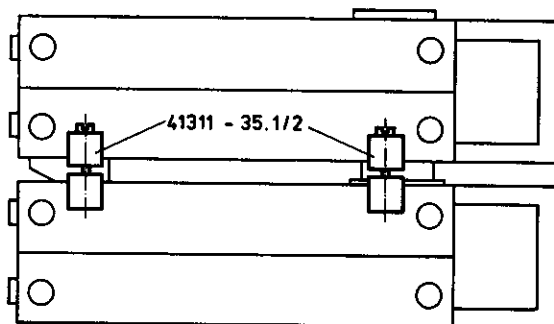

Fig. 1-3 Connection of two instruments

If the **sidewalls** are **not perforated**, withdraw the instrument from the cabinet and mark and drill the required holes according to the two templates provided. Use template 41311-35.3/2 ("vorn") for the front corners and 41311-35.2/2 ("hinten") for the rear corners.

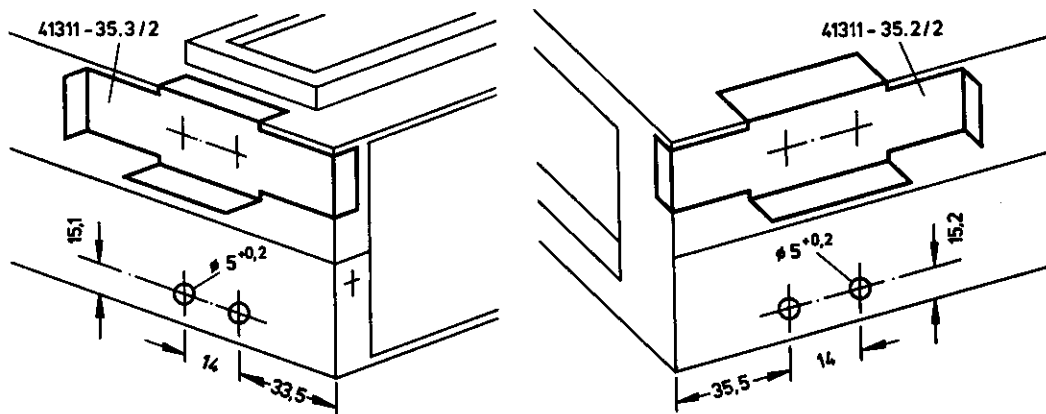

Fig. 1-4 Templates

Four blocks 082.5476.02 are required for screwing together two instruments. Four more such blocks must be used for each additional unit.

2. Preparation for Use and Operation

2.1 Table of Controls (see Figs. 2-1 and 2-2)

Ref.	Engraving	Function
1	401 to 484 MHz 293 to 404 MHz 183.5 to 294.5 MHz 129 to 184.5 MHz 74 to 129.5 MHz 47 to 74.7 MHz 0.4 to 48 MHz	Pushbuttons for frequency-range selection with recessed screws for calibration. Calibration is accomplished by adjustment of the pointers.
2	MHz	Frequency dial, consisting of the drum with engraved frequency scales and of pointers. Only the pointer associated with the range selected with 1 is visible. The frequency ranges can be calibrated with the screws recessed in the frequency buttons 1.
3	INDICATION $\varphi M [\Delta f/f_{MOD}]$ FM [kHz] MOD. GEN. $\times 10$ [mV] AM [%]	Switch for selecting the type of indication of the meter: modulation index $\Delta f/f_{mod}$, frequency deviation in kHz, AF output voltage at 20 (mV), modulation depth in %.
4	INDICATION 1 4 10 40 100	Range selector for meter 5. In mode of operation AM, the ranges 1 and 4 are used for checking purposes only; the indicated values are not guaranteed.
5		Meter for the ranges selected with 3 and 4.
6	MOD. OFF	This button permits the modulation to be cut off to check whether the receiver connected is correctly tuned to the signal generator.
7	MOD. GEN. 0.3/0.4/0.7/1/1.3/1.5/ 1.75/2.07/2.4/2.7/3/6 kHz	Selector for internal modulation frequency.
8	AMPLITUDE MOD. GEN.	Knob for the adjustment of the modulation-generator output voltage available at 20; the amplitude of the output voltage is indicated on meter 5 if 3 is at MOD. GEN. The modulation generator is in operation when the FM/ φM switch 19 or the AM Switch 9 is in the position INT. or UNMOD.

Ref.	Engraving	Function
9	AM INT. UNMOD. EXT.	Selector for type of amplitude modulation: INT. = modulation with an internal frequency of the SMDA selected with 7 (modulation generator in operation). UNMOD. = no modulation (mod. gen. in operation). EXT. = modulation with external signals applied at 26 (mod. gen. not in operation if switch 19 is also in position EXT.)
10	FREQ. FINE	Knob for fine tuning of the modulation generator frequency selected with 7 (fine tuning range: -30 Hz to +400 Hz). At the left stop (CAL.) the knob is disabled, i. e. the modulation generator frequency is that selected with 7.
11	AM	Knob for continuous adjustment of modulation depth. The types of amplitude modulation are selected with 9.
12		Fine scale of attenuator; calibrated in steps of 0.2 dB for adjusting small level differences (see also item 17).
13		Knob for the adjustment of the RF output voltage.
14	POWER	Button for switching on the AC supply voltage.
15		Lamp lights when the set is switched on.
16	OUTPUT $R_i = 50 \Omega$	Output socket for the RF voltage (adaptable). The level of the output voltage can be read on 17.
17	OUTPUT U_A 50Ω 6 dB dBV EMK	Scale reading the level adjusted with the RF output control 13. The RF output voltage is available at 16. In the range outside the black mark, the fine scale of attenuator 12 can be used for the interpolation of level differences; the specified VSWR is maintained. From -20 dBV the line for E_{out} into 50Ω on the cursor of the attenuator applies. NOTE: The attenuator is calibrated in V_{EMF} , the line for E_{out} into 50Ω may have an error of ± 1 dB. • < 1 W: Attenuator setting for frequency deviation measurements with the test assembly for radiotelephone systems when the input to the Power Test Adapter is < 1 W.

Ref.	Engraving	Function
		● > 1 W: Attenuator setting for frequency deviation measurements with the test assembly for radiotelephone systems when the input to the Power Test Adapter is > 1 W.
18	φ M, FM	Knob for continuous adjustment of frequency deviation and modulation index. The types of modulation are selected with 19.
19	FM INT. EXT. φ M EXT. INT. UNMOD.	Selector for type of phase and frequency modulation: INT. = modulation with the internal frequencies of the SMDA selected with 7 (modulation generator in operation). UNMOD. = no modulation (mod. gen. in operation). EXT. = modulation with external signals applied at 28 (mod. gen. not in operation if switch 9 is also in position EXT. At $f_{\text{mod}} = 1$ kHz, the frequency deviation is the same for φ M and FM (level adjustment frequency).
20	MOD. GEN. OUTPUT	Modulation-generator output socket. The amplitude of the output voltage can be adjusted with 8 and read on 5 if 3 is at MOD. GEN. x 10 mV. Modulation generator only in operation if the FM switch 19 and the AM switch 9, respectively are at INT. or UNMOD. It is switched off, if both switches are in position EXT.
21	$\Delta f > \Delta f_{\text{MAX}}$	Pilot lamp which lights if the maximum frequency deviation of 75 kHz is exceeded with phase or frequency modulation (switch 19).
22		Pilot lamp of overload protection; lights or blinks if RF power is fed to output 16.
23		Incremental tuning knob. The frequency is indicated on scale 2, the frequency increment on scale 25.
24		Coarse tuning knob. Incremental tuning with 23. The frequency is indicated on scale 2.
25		Incremental tuning scale calibrated in kHz. The adjustment is correct if the cams having the same colour as the pointers of the frequency range concerned coincide. The figures appearing in the windows give the frequency increment in kHz.

Ref.	Engraving	Function
		The incremental tuning scale can be set to 0 from any position while the incremental tuning knob 23 is held in its position; the pointer can be adjusted by $\pm 45^\circ$.
26	AM EXT. $R_E \approx 600 \Omega$, $U_E \approx 1.5 \text{ V}$	Input socket for external AM signal. Switch 9 must be at AM EXT. Modulation depth can be selected with 11 . Voltage requirement approx. 1.2 V into 600Ω (for 95 % modulation).
27	SWEEP INP. MAX. 10 V, $R_E \approx 2 \text{ k}\Omega$	Input socket for applying a sweep voltage. The sweep frequency may be 0 to 1 kHz. The sweep width is indicated on Frequenzkontroller 100.4542.
28	FM EXT. $R_E \approx 600 \Omega$	Input socket for external FM signal or phase modulation. Switch 19 must be at FM EXT. or ϕM EXT. Frequency deviation can be selected with 18 . Voltage requirement approx. 2.5 V into 600Ω (for maximum sweep width).
29	CALIB.	Meter for calibration of the lower frequency range by the beat method.
30	AC SUPPLY KONTROLLER	AC supply voltage output for connection of the Frequenzkontroller, which is switched on together with the signal generator.
31	VOR-ILS UNIT	Output for connection of a VOR-ILS Unit 214.3115 for ATC purposes.
32		Chassis socket
33	RF OUTPUT II	A frequency-modulated signal is available at this output. This signal is mainly used as an input signal for the Frequenzkontroller. It may also be fed to a frequency meter, deviation meter, counter, etc. The output voltage is independent of the output-attenuator setting.
34	SYNCHRONISATION KONTROLLER	Multipoint connector for the control lines of the Frequenzkontroller.
35	SYNCHRONISATION	Input (BNC) for the connection of the control voltage of the Frequenzkontroller, used for the synchronization of the SMDA.
36	AC SUPPLY ADAPTER	AC supply voltage output for connection of the Power Test Adapter or VOR-ILS Unit, which are switched on together with the signal generator.

Ref.	Engraving	Function
37	110 V M 0,2 C 125 V 220 V M 0,1 C 235 V	Tapping panel with power fuse (upper right-hand corner) and fuse container.
38	AC SUPPLY	Receptacle
39 40	± 24 V 500 mA	Sockets for connection of battery.
41 42	± 24 V 120 mA	Sockets for connection of battery.

2.2 Adjusting to the Local AC Supply Voltage

Type SMDA has been built in compliance with the safety regulations according to VDE 0411 Class I. Class I requires insulation of the AC supply during operation. In addition, all exposed conducting elements that are likely to be immediately alive in the case of a failure must be properly and permanently connected with each other and with the non-fused earthed conductor. The power plug should therefore be inserted only into an earthing contact type socket. Do not interrupt the non-fused earthed conductor when using extension lines. Connect the terminal, if any, permanently to a non-fused earthed conductor.

The SMDA is factory-adjusted for operation from 220 V. Prior to switching on make sure that the tapping panel **37** (Fig. 2-2) is adjusted for the available AC supply voltage. The four AC supply voltages selectable are engraved in the four corners of the fuse box. The line beside the screw cap in the upper right-hand corner must point to the value of the available AC supply voltage (turn the box correspondingly). To adjust for a different AC supply voltage or to change a fuse proceed as follows:

- a) Unscrew the screw cap with the power fuse (upper right-hand corner) from the tapping panel **37**.
- b) Remove cover plate of tapping panel **37**.
- c) Take the appropriate fuse from the fuse container on the inside of the cover plate and insert it into the screw cap.
- d) Introduce the bolt of the cover plate **37** into the guide hole and turn the cover plate until the marking line points to the corresponding value.
- e) Tighten screw cap.

Two fuses are provided for 220/235 V AC supply and two for 115/125 V. If the same AC supply voltage is always used only one type of spare fuses may of course be stored in all three containers. A fine-wire fuse M 0,1 C DIN 41571 is used for 220 or 235 V and a fine-wire fuse M 0,2 C DIN 41571 for 115 or 125 V.

Variations of the AC supply voltage of $\pm 10\%$ from the rating do not affect the performance of the set as specified in 1.3. Heavier fluctuations should be avoided or a transformer or voltage stabilizer should be connected ahead of the signal generator. The set is switched on with button **14** (Fig. 2-1). When the set is switched on and the power fuse is intact, lamp **15** lights.

2.3 Adjusting the Zero of the Meter

If the set is switched off the pointer of the meter **5** should be at scale zero. Correct, if necessary, with the recessed screw below the meter. Before checking or adjusting the zero, wait at least 3 minutes after the SMDA has been switched off in order to ensure that the charging capacitor of the meter circuit is completely discharged. The electrical zero is identical with the mechanical zero. Meter **29** serves as an indicator; the zero (arrow) cannot be corrected.

2.4 Frequency Setting

2.4.1 Adjusting the Frequency of the RF Oscillator

Select the frequency range with the corresponding button **1**. The frequency ranges are indicated beside the buttons. When a button is pressed, a pointer appears on the corresponding scale. Adjust the frequency first roughly with the coarse tuning knob **24** and then to the exact desired value with the incremental tuning ring **23**.

2.4.2 Calibration of the Frequency Scale

The pointers of the frequency scale can be adjusted with the screws recessed in the buttons **1**. When using one of the lower two frequency ranges – where the output frequency is obtained by the beat method – a check of the zero frequency which is marked by a red line on the frequency scale is recommended:

When the pointer is near the red line, tune the SMDA to zero beat, using the incremental tuning ring **23**. At zero beat the pointer of the meter goes back to 0 which is marked by the direction of the arrow. A sudden, large pointer deflection indicates that the zero beat is exceeded in either direction. If the SMDA is adjusted to zero beat, the pointer of the frequency scale can be set exactly to the red zero line by means of the corresponding screw. After this calibration, the specified frequency accuracy is attained also in the lower two ranges. In the other ranges, an adjustment of the pointer is recommended only if an accurate frequency meter is available, because of the high frequency stability of the SMDA. The calibration may, however, also be carried out to ensure particularly high frequency accuracy, corresponding to the reading accuracy of the scale, in the vicinity of a particular operating frequency. For example, in operating with a crystal-controlled channel receiver, the SMDA can be accurately calibrated for the channel frequency used; a considerable improvement in frequency accuracy will then result also for the adjacent channels.

2.4.3 Incremental Tuning

The SMDA has an incremental tuning facility **25** calibrated in kHz. Since the bandwidths of the frequency ranges differ, the value corresponding to one scale division is also different in each frequency range. For this reason, the incremental tuning scale is provided with windows in which the values applicable for the frequency range selected are shown. The scale dial and the figure dial behind it are provided with cams marked by corresponding colour dots. If the two cams marked by the same colour as the pointer of the frequency scale **2** are brought to coincidence, the figures applying to the frequency range concerned appear in the windows; for example 50 and 100 are obtained when the cams marked green

coincide, corresponding to the green pointer for the frequency ranges 74 to 129.5 MHz and 129 to 184.5 MHz. The spacing between two long lines then corresponds to 10 kHz. The incremental tuning scale can be set to 0 for the measurement of frequency increments. In addition, the pointer can be shifted without changing the tuning, in order to avoid unwanted detuning of the signal generator during rotation of the incremental tuning scale when a fine correction is made or the zero shifted by a small defined amount, say, in order to refer the zero to an adjacent channel.

2.5 Output Voltage Adjustment

2.5.1 Setting the RF Output Voltage and Taking the Reading

The output voltage can be adjusted with knob **13** and is available at socket **16**. The upper volt scale of **17** reads twice the voltage into a 50- Ω load. The lower scale reads the EMF in dB below 1 V (dBV). This EMF calibration ensures that errors in the output impedance caused by varying film thickness of the output potentiometer are taken into account in the calibration of the output-voltage scale. Any additional error due to variation of the frequency-independent output impedance are thus avoided.

Small level differences below -20 dBV can be easily adjusted with the fine scale **12** of the attenuator knob. The fine scale is calibrated in 0.2-dB steps and the volt scale in 0.1-V steps. One rotation of the fine scale (10 dB) may cause an error of ± 0.8 dB, i. e. the EMF or dBV calibration of the scale may differ from the fine scale by this amount. On scale **17**, a shorter line for E_{out} into 50 Ω is engraved at 6 dB to the right from the long line for EMF and dBV. As the scale is calibrated in V_{EMF} and dBV, the line for E_{out} into 50 Ω may have an additional error of ± 0.5 dB, due to the constant surface resistance of the attenuator.

VSWR is approximately 2.5 with maximum output voltage and < 1.3 with attenuator settings > 10 dB (level range outside the black mark). (These values hold true for Dezifix A connectors only). Although the special calibration of the output attenuator largely compensates for the error resulting from this VSWR, a smaller VSWR is desired in certain precision measurement and in cases where the SMDA must constitute a reflection-free termination for the load. In this case, the interconnection of 10-dB Attenuator Pads Type DPF 100.1795.50, equipped with Dezifix A connectors, is recommended to reduce the reflection coefficient to about 5 to 3%, depending on the output-attenuator setting.

2.5.2 Connecting the Load

The RF output **16** of the SMDA is fitted with an N connector, therefore a cable with an N connector is required for the connection of a load. Care should be taken that the N connectors are not damaged by shocks or blows. The face of the connectors should always be kept clean; this makes for better contact and reduces the reflection coefficient. If an optimum RF connection and minimum reflection coefficient are not essential, the other end of the cable can be adapted to the output connector or the test item. Should it not be possible to connect the test items with N connectors, the RF output **16** of Type SMDA can be adapted for use with other connector systems, as described in section 2.5.6.

No DC or AC voltage must be applied to the SMDA from the load. If a voltage of ≥ 2 V is applied to the RF output socket **16**, this output is cut off from the SMDA. Smaller voltages, from about 0.1 V on, may disturb the automatic output level control if the output attenuator **13** is set to maximum. If only part of the output attenuator is cut in, the RF voltage fed to RF output **16** may be higher by the attenuation ratio but not exceed approx. 2 V. Type SMDA con-

tains a coaxial relay which disconnects the signal-generator output from the output socket 16 as soon as the voltage fed into this socket exceeds a few volts.

The RF output 16 of Type SMDA is also protected against any DC voltages applied inadvertently. If the output attenuator is set to maximum, a DC voltage of 20 V does not cause damage and with output voltages below 0.1 V up to 250 V DC may be applied. If the DC voltage fed to the output socket exceeds approx. 2 V, the output of the SMDA is cut off.

2.5.3 Voltage at the Load

If the input impedance of the test item is complex and does not exactly agree with the source impedance of the signal generator, the voltage E at the load can be calculated from the open-circuit voltage EMF adjusted on the signal generator and the complex input impedance Z_I of the load:

$$E = EMF \frac{Z_I}{Z_I + Z_S}$$

This formula applies if the characteristic impedance of the cable connecting the load is equal to the signal-generator output impedance (50 Ω) and with attenuator settings < 10 dB. It is advisable to select the load impedance equal to the source impedance of the signal generator. Then the voltage at the load is half the EMF adjusted and indicated on the signal generator (also with levels > -10 dBV). The output impedance of the signal generator is 50 Ω . The cable impedance, contact resistances and other discontinuities are negligible. The conversion factors for the voltage and the level at the load for different terminating resistances are given in Table 1.

R_l Ω	k	a_{k2} dB
50	0.5	6
60	0.545	5.3
75	0.6	4.4
150	0.75	2.5
240	0.828	1.6
600	0.92	0.7

Table 1: Conversion factors for voltage and level at the load with different load resistances

- | | |
|------------------------------------------------|-----------------------------------------------------------------------|
| R_l = input resistance of load | k_l = conversion factor |
| E_l = voltage at the load | a_{k2} = dB values to be subtracted with different load resistances |
| a_l = level at the load | Voltage at the load $E_l = EMF k_l$ |
| EMF = EMF adjusted on the signal generator | Levels in dB at the load $a_l = a_E - a_{2k}$ |
| a_E = level adjusted on the signal generator | |

2.5.4 Power Consumption of the Load

The RF output scale 17 indicates the voltage offered by the SMDA to an ideal load, in dB below 1 V (dBV). This way of specifying the level is particularly advantageous since slight mismatch of the load to the voltage source has very little influence on the power consumed. The power drop caused by a different characteristic impedance is almost negligible. As can be seen in Fig. 2-3, a mismatch of $Z_l/Z_s = 1/3$ results in a power drop of about 2.5 dB, $Z_l/Z_s = 1/2$ produces a power drop of 1 dB.

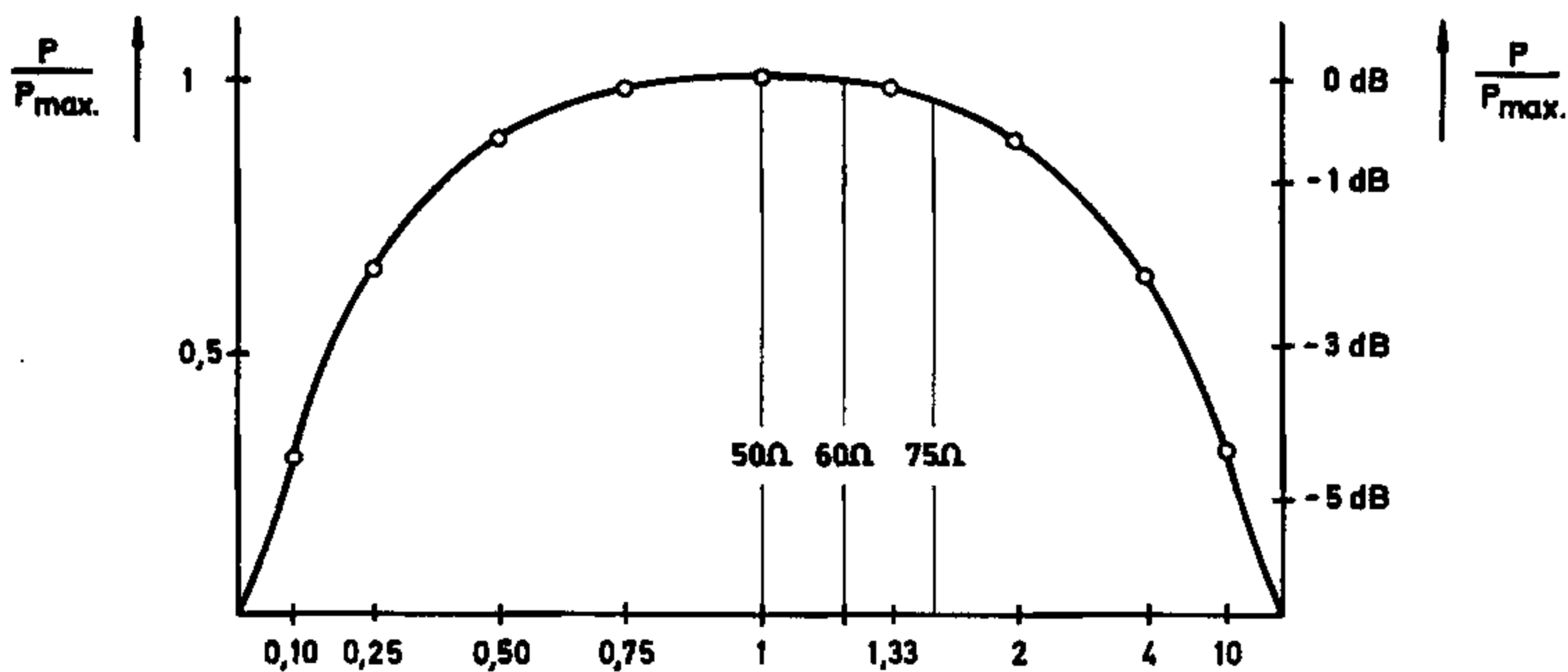

Fig. 2-3 Active power in case of mismatch

2.5.5 Adjusting Extremely Small Output Voltages

The high-quality output attenuator and good shielding of the SMDA make accurate setting of extremely small output voltages possible. Whether these small voltages arrive at the input stage of the test item or whether they are invalidated by superimposed noise voltages depends on the test item and the cables used. In general, noise voltages can be prevented by good shielding of the test item, use of short connections (no cables, if possible) and AC supply from twin wall sockets. Noise voltages may develop as follows:

Noise voltage sources: Two types of noise voltage are distinguished by their sources: noise voltages developing from hum pickup and noise voltages caused by inductive leakage. Fig. 2-4 illustrates the development of a noise voltage. The noise voltage E_s is effective at the load input if the noise current I_s on the outer conductor of the cable with an impedance Z_K causes the voltage drop $E_s = I_s Z_K$. The noise voltage source E_Q is somewhere in the noise voltage loop formed by Z_1 , Z_K and Z_2 .

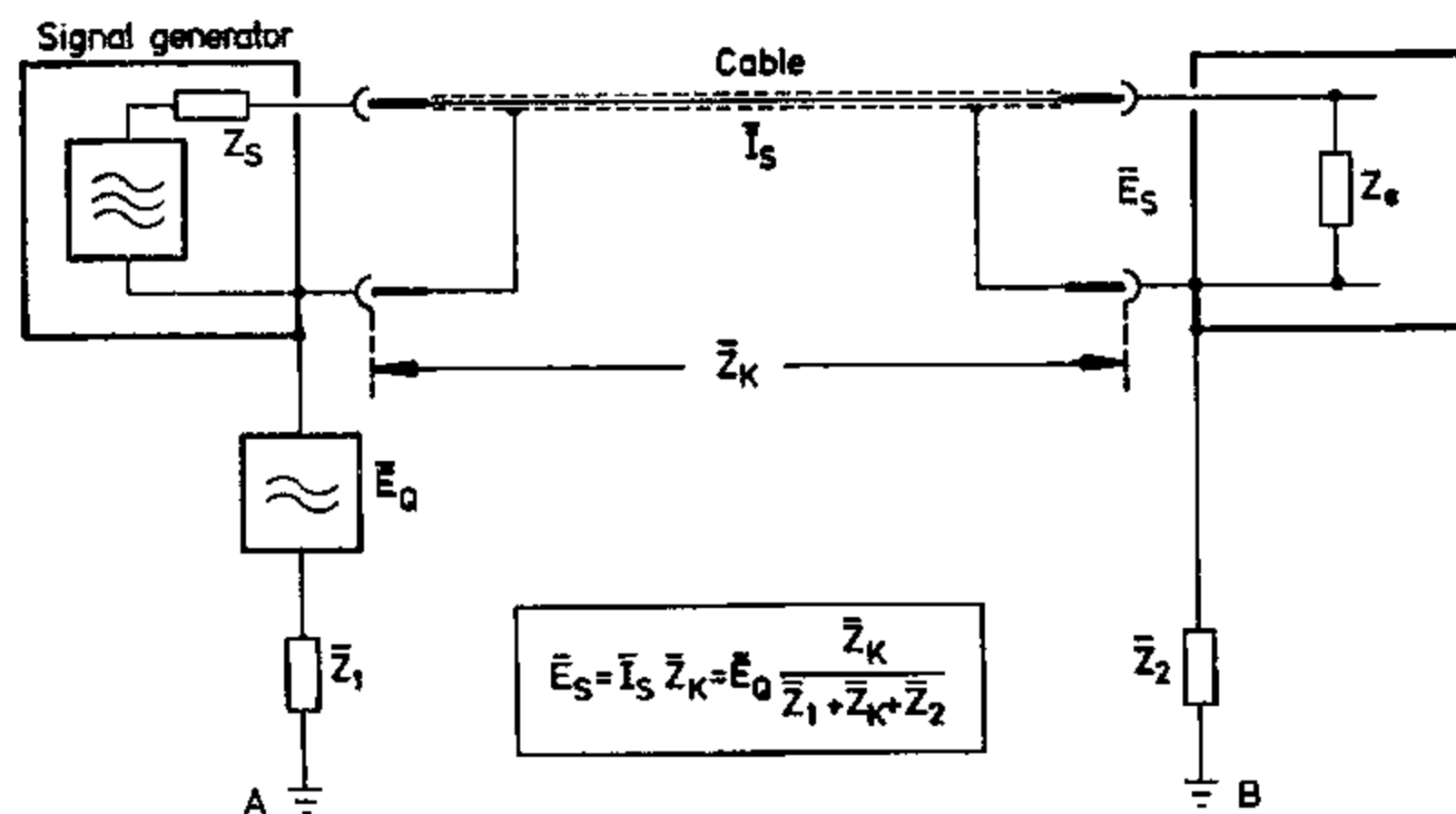

Fig. 2-4 Simplified equivalent diagram of noise voltage source

This equation shows that the noise voltage at the load decreases with decreasing noise source E_Q and impedance Z_K and with increasing earth wire impedances Z_1 and Z_2 . Since Z_1 and Z_2 must be kept small for reasons of safety the impedance Z_K must be minimized. The impedance Z_K depends not only on the cable jacket and on the contact resistances of the outer conductor but also on the shielding of the input stage of the test item. The shielding and connection to the outer conductor of the connecting cable should be short and of low impedance.

The noise voltage source E_Q may exist between the earthing points A and B if the neutral conductor of the AC supply is at the same time used as a non-fused earth conductor. If the signal generator and the test item are earthed at different points of the AC supply, the voltage drop between A and B (Fig. 2-4) may also be caused by the power consumption of a third load. Noise voltages of a frequency of 50 Hz and its harmonics then result. The noise source can be avoided by minimizing the distance between points A and B (twin socket). Noise voltages can be induced in the hum-pickup loop Z_1, Z_K, Z_2 by inductive leakage of power transformers or poorly shielded RF voltage sources. These noise voltages can be prevented by making the pickup loop as short as possible by suitable wiring.

2.5.6 Adapting the RF Output 16 to Other Connector Systems

The output 16 of the SMDA can readily be adapted, according to data sheet 902110, to suit other connector systems. Simply unscrew the end pieces of the outer and inner conductors of the N socket and replace them by the corresponding parts of the desired connector.

Data sheet 902110 lists the connector systems for which screw-in assemblies are available. The specified stock numbers serve as order numbers for a complete screw-in assembly (inner conductor and outer conductor). Attention is drawn to the fact that the conversion of the N connector into another system, with the exception of Dezifix A, affects the reflection coefficient of the output and possibly the RF leakage.

2.6 Modulation Generator

2.6.1 Frequency Setting

The fixed frequency of the built-in modulation generator can be adjusted with switch 7. Each fixed frequency can be finely tuned over a range from -30 Hz to $+400$ Hz by means of knob 10. Thus any desired frequency between 270 Hz and 3.4 kHz may be adjusted. The fine tuning can be read from the engravings provided around the knob. The frequencies selected with switch 7 are accurate to within $\pm 1.5\%$ only if knob 10 is at the left stop (CAL.). The voltage of this AF generator can be used for internal AM, φ M or FM (switch 9 or 19 at INT.) and is available at output 20 for measurements. The built-in modulation generator is in operation if at least one of the switches FM 19 or AM 9 is at INT. or UNMOD.

2.6.2 Voltage Setting

In position AM INT., FM INT., AM UNMOD. or FM UNMOD., the output voltage of the RC oscillator is available at output 20. Knob 8 ganged with the shaft of a logarithmic potentiometer serves for the adjustment of the output voltage. To measure the output voltage, set switch 3 to the centre position MOD. GEN. $\times 10$ [mV]. Select the range of indication with 4 and read the output voltage on meter 5. The full-scale meter deflections in the different ranges correspond to the following voltages:

Full-scale value	voltage
1	10 mV
4	40 mV
10	100 mV
40	400 mV
100	1000 mV

Table 2 Range of indication

Voltage between 0.5 and 1000 mV are thus readily adjustable.

2.7 Types of Modulation

2.7.1 Frequency Modulation

Frequency modulation is selected with the FM switch **19**. In the INT. position of **19** the built-in modulation generator is used and in the EXT. position an external voltage may be fed into socket **28** for the modulation of the SMDA. To ensure that the SMDA operates free from interferences in the unmodulated mode, set the two switches **9** and **19** to EXT. The modulation generator is then inoperative. In the FM INT. position, the modulation frequency can be selected on the built-in modulation generator according to section 2.6.1. The external or internal modulation can be interrupted with button **6**. Thus it is easy to find out whether the signal present in a connected receiver comes from the SMDA.

In the FM EXT. position of switch **19** an AF signal between 30 Hz and 20 kHz must be fed to the FM EXT. socket **28**. With modulation frequencies > 20 kHz and < 30 Hz, performance complying with the specifications of section 1.3 is no longer guaranteed. The voltage required for maximum deviation is about 2.5 V into 600 Ω . The voltage applied to socket **28** should not be greater than 3 V since otherwise the deviation cannot be properly adjusted with potentiometer **18**. The permissible load limit is 30 V_{pp}.

The frequency deviation adjusted with knob **18** is read in kHz on meter **5**. The INDICATION switch **3** must be at FM. The range selector **4** should be set to the lowest range possible with the desired deviation in order to avoid appreciable reading errors. If the maximum frequency deviation of 75 kHz is exceeded, the lamp **21** lights up. Simultaneous amplitude and frequency modulation of the SMDA is possible according to the switch positions of **9** and **19**.

2.7.2 Phase Modulation

Phase modulation is selected with switch **19**. In the position ϕ M INT. of the switch, the built-in modulation generator is used and in the position ϕ M EXT. an external signal can be fed into socket **28** for the modulation of the SMDA. To ensure that the SMDA operates free from interferences in the unmodulated mode, set the two switches **9** and **19** to EXT. The modulation generator is then inoperative. In the position ϕ M INT., the desired modulation frequency is adjusted on the built-in modulation generator according to section 2.6.1. By depressing push-button **6**, external or internal modulation may be switched off to check whether the signal present in a connected receiver comes from the SMDA.

In the position ϕ M EXT. of switch **19**, an AF signal between 30 Hz and 10 kHz can be applied to socket **28**. At modulation frequencies > 10 kHz and < 30 Hz, the specifications according to section 1.3 are no longer guaranteed. The voltage required for maximum frequency deviation is approximately 2.5 V at a modulation frequency of 1 kHz. At other modulation frequencies, the voltage required is correspondingly greater or smaller. The maximum permissible input voltage at socket **28** is 30 V_{pp}.

The level adjustment frequency is 1 kHz, i. e. at a modulation frequency of 1 kHz, the frequency deviation is the same for ϕ M and FM if the modulation voltage is the same. The modulation index $\Delta f/f_{\text{mod}}$ which is adjusted with knob **18** can be read on meter **5**. For this purpose, the type-of-indication selector **3** must be in position ϕ M. It is also possible to measure the frequency deviation in the phase modulation mode. To do so, set switch **3** to FM. If the maximum frequency deviation of 75 kHz is exceeded, pilot lamp **21** lights up. To avoid appreciable indicating errors, the indicating range selector **4** should be in a position corresponding to the lowest range possible with the selected modulation index or frequency deviation. Simultaneous amplitude and phase modulation of the SMDA is possible with the switches **9** and **19** adjusted accordingly.

2.7.3 Amplitude Modulation

Amplitude modulation is selected with the AM switch 9. In the INT. position of 9 the built-in modulation generator is used and in the EXT. position an external signal can be fed into socket 26 for the modulation of the SMDA. To ensure that the SMDA operates free from interferences in the unmodulated mode, set the two switches 9 and 19 to EXT. The modulation generator is then inoperative. In the FM INT. position, the modulation frequency can be selected on the built-in modulation generator according to section 2.6.1. In the EXT. position an AF signal between 30 Hz and 10 kHz must be fed to the AM EXT. socket 26. With modulation frequencies > 10 kHz and 30 Hz, performance complying with the specifications of section 1.3 is not guaranteed. The voltage required for 80 % modulation is about 1.2 V into 600 Ω. The voltage applied to socket 26 should not be greater than 1.5 V since otherwise the modulation depth cannot be properly adjusted with potentiometer 11. The modulation depth adjusted with knob 11 is read on meter 5 in per cent. The INDICATION switch 3 must be at AM. The range selector 4 should be set to the lowest range possible with the desired modulation depth in order to avoid appreciable reading errors.

The indicated modulation depth is the ratio of the voltage of the envelope U_H of the modulated RF carrier to the voltage U_T of the unmodulated RF carrier. The peak values of both voltages are used in the equation:

$$m [\%] = \frac{U_H}{U_T} \times 100 \%$$

2.8 Frequency Deviation Measurement with Frequenzkontroller BN 413115

If for the automatic frequency deviation measurement Frequenzkontroller of former design (BN 413115) are to be used, an additional resistor must be soldered into the subassembly deviation meter 413115-9.20 (in the Frequenzkontroller).

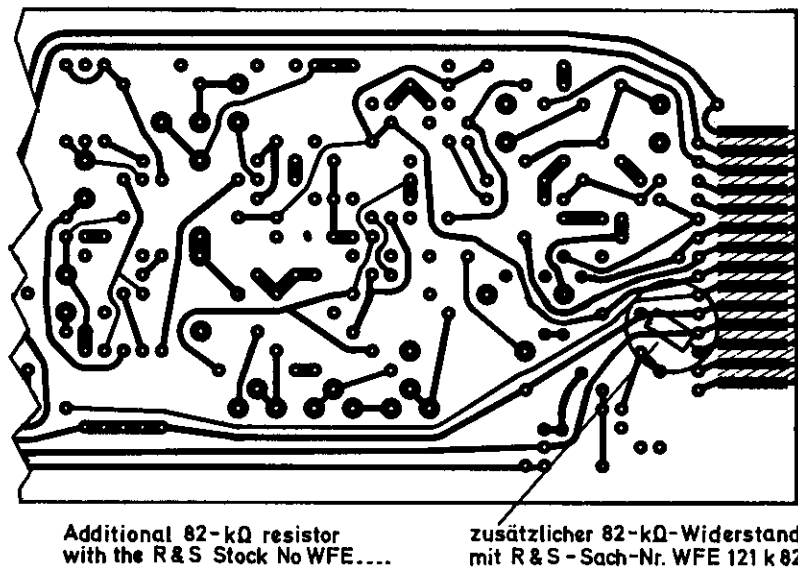

Fig. 2-5 Subassembly deviation meter 413115-9.20

3. Maintenance

The mechanical construction of Type SMDA is such that no maintenance is necessary. In case any mechanical defects develop, we recommend that the signal generator be sent to the local R & S agency or to the R & S factory. This is absolutely necessary if a scale, oscillator or attenuator drive is defective. The mechanical work (cleaning, disassembling) involved in the maintenance of the signal generator is described in section 3.3.

3.1 Measuring Instruments and Auxiliary Equipment Required

The following table lists all measuring instruments and auxiliary equipment required for checking.

Designation and specifications	Type	Ident No.	Uses Section
UHF-DC Millivoltmeter AC voltage 2 mV to 300 V Frequency range 1 kHz to 1.6 GHz Error of voltage indication $\pm 8\%$ of f.s.d. DC voltage 1 mV to 1000 V Error of voltage indication $\pm 8\%$ of f.s.d. with probe (above 300 MHz to be used as indicator only - appreciable error)	URV	100.0130.02	3.2.1.2 3.2.4
Millivoltmeter Frequency range 10 Hz to 1 MHz Voltage range 0.1 mV to 300 V, -80 to +52 dB Error of voltage indication $\pm 2\%$ of f.s.d. Input resistance 1 M Ω , shunted by 30 pF.	UVN	100.0160.02	3.2.2.2 3.2.2.3 3.2.3.12
Digital Multimeter AC voltage 100 μ V to 700 V _{rms} Frequency range 20 Hz to 20 kHz DC voltage 100 μ V to 1000 V Resistance range 1 to 15 M Ω	UGWD	100.0218.02	3.2.8
Power and Standard Signal Generator Frequency range 30 kHz to 31 MHz Output voltage EMF 0 to 10 V into 60 Ω	SMAR	100.4513.02	3.2.3.5 3.2.3.6
VHF Signal Generator Frequency range 22.5 to 480 MHz Output voltage EMF 0 to 3.5 V into 60 Ω	SLSV	100.4188.02	3.2.1.6 3.2.3.5 3.2.3.6
Stereo Signal Generator Frequency range I 10.2 to 11.2 MHz II 87 to 108 MHz Output voltage EMF I 0.1 mV to 1 mV II 0.1 mV to 1 V	SMSF	100.4571..	3.2.1.6
Field-Strength Meter Frequency range 0.1 to 30 MHz Voltage range 0 to 120 dB above 0.1 μ V (0.1 μ V to 0.1 V)	HFH	100.1014.02	3.2.1.3 3.2.1.4 3.2.1.6

Designation and specifications	Type	Ident Nö.	Uses Section
VHF-UHF Monitoring Receiver with the 4 RF Plug-in Units 100.1189.02 at 25 to 230 MHz 100.1195.02 at 160 to 470 MHz 100.1208.02 at 460 to 900 MHz 100.1214.02 at 850 to 1300 MHz Input voltage for all RF Plug-in Units 0 to 120 dB above 1 μ V (1 μ V to 1 V)	ESU	100.1143.02	3.2.1.3 3.2.1.4 3.2.7.1 3.2.7.2
Frequency Deviation Meter Frequency range 20 to 300 MHz Deviation range 0 to 150 kHz	FMV ¹⁾	100.5932.02	3.2.1.5 3.2.3.5 3.2.3.6 3.2.3.7 3.2.6
Direct-Reading Distortion Meter Measurement range 0.2 to 30 % Frequencies 0.04/1/5/15 kHz	FTZ	100.6100.02	3.2.3.4 3.2.3.7
Wave Analyzer Frequency range 5 Hz to 20 kHz Voltage range 1 μ V to 300 V	FAT 1	100.8683 ..	3.2.2.4 3.2.3.4
Frequency Indicator Frequency range 10 Hz to 500 kHz Error ± 1 %	FKM ¹⁾	100.5955.02	3.2.1.6
800-MHz Counter with 800-MHz Plug-in 100.6080.02 Frequency range 10 to 800 MHz Error limits $\pm 10^{-10}$	FET 2 ¹⁾	100.6039.02	3.2.1.1 3.2.1.6 3.2.2.1
Frequency Counter Frequency range 10 kHz to 350 MHz Error limits $\pm 5 \times 10^{-10}/^{\circ}\text{C}$	FET 3 ¹⁾	104.0235 ..	3.2.1.1 3.2.1.6
Interference Meter Type U 2033 or J 78 of Siemens with weighting filter according to CCIF 0.3 to 3 kHz			3.2.1.5
Demodulator Type Narda, Model 501 BR			3.2.3.4
SHF Termination	RMC	100.2940.50	3.2.4
Battery (2 ea) 24 V, $I_{\text{max}} = 0.5$ A Adapter ($Z = 50 \Omega$) N connector system \longleftrightarrow Dezifix B ²⁾ Dezifix B ²⁾ \longleftrightarrow Subminax socket Dezifix B ²⁾ \longleftrightarrow Subminax plug Cable ($Z = 50 \Omega$) Dezifix B ²⁾ \longleftrightarrow Subminax plug Dezifix B ²⁾ \longleftrightarrow Subminax socket N connector system \longleftrightarrow Dezifix B ²⁾ Dezifix B ²⁾ \longleftrightarrow Dezifix B ²⁾ BNC \longleftrightarrow 4/13 ²⁾			

¹⁾ Can be replaced by the Frequenzkontrolller 100.4542

²⁾ These connectors apply to R&S instruments only

3.2 Performance Check

3.2.1 RF Output

3.2.1.1 Frequency

Test setup

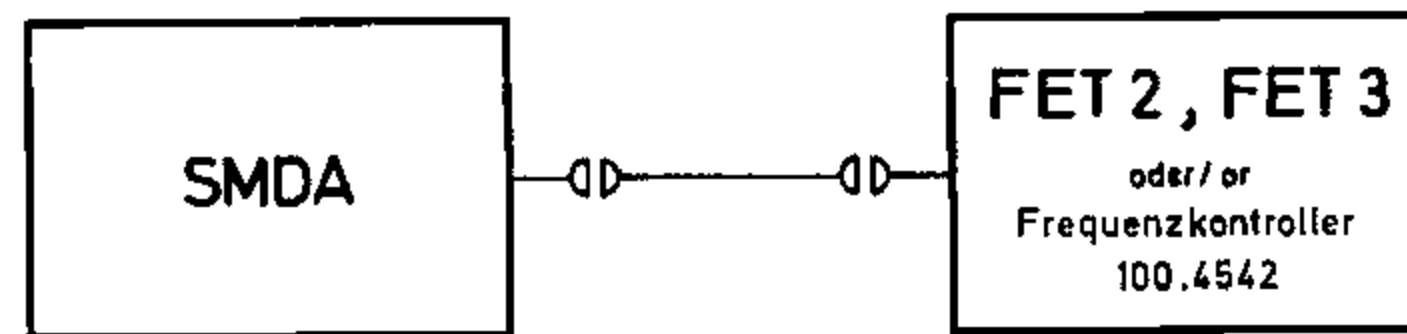

Fig. 3-1 Test setup for frequency measurement at the RF output

Measurement: Check the frequency at three points in each range (upper limit, centre and lower limit). Prior to checking in range I, calibrate the frequency scale (zero beat adjustment). Allow a warm-up period of 5 minutes after switching on and after range switching.

Permissible errors: of measured frequency relative to the frequency setting of the SMDA: Range I (0.4 to 48 MHz) $< \pm(1.5\% + 100 \text{ kHz})$, Ranges II to VII $< \pm 0.5\%$

Adjustment: If all departures are in the same direction, correct with the adjustment screws provided in the frequency-range buttons. If the directions of the departures vary, adjust the oscillator concerned according to section 5.4.2.

3.2.1.2 Checking the Output Voltage or Output Power

Test setup

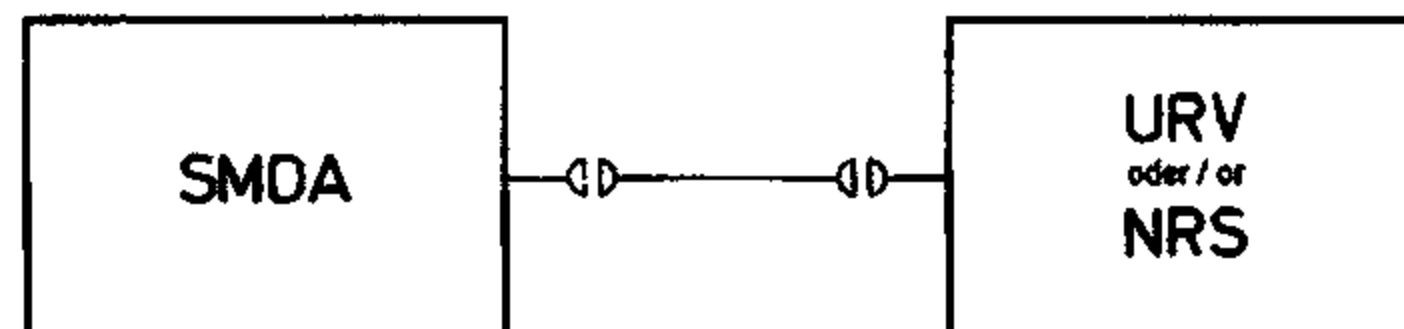

Fig. 3-2 Measurement of output voltage or output power at the RF output

Measurement: Measure the output voltage (or output power) in the lower third and at the upper limit of each frequency range with the output attenuator of the SMDA set to 0 dBV.

Permissible errors: of measured voltage or power relative to the setting of the SMDA $< \pm 0.6 \text{ dB}$. (This error includes the amplitude/frequency response in the whole frequency range.)

Adjustment: If all departures are in the same direction, correct with potentiometer R273 in the AGC amplifier (see section 5.4.4 and Fig. 4-1). If the directions of the departures vary (amplitude/frequency response), there is probably a defect in the coupling head (G1260 in 41314 S Bl.2) of the attenuator (see section 5.3.11).

3.2.1.3 Measuring the Non-harmonic Spurious Waves

Test setup

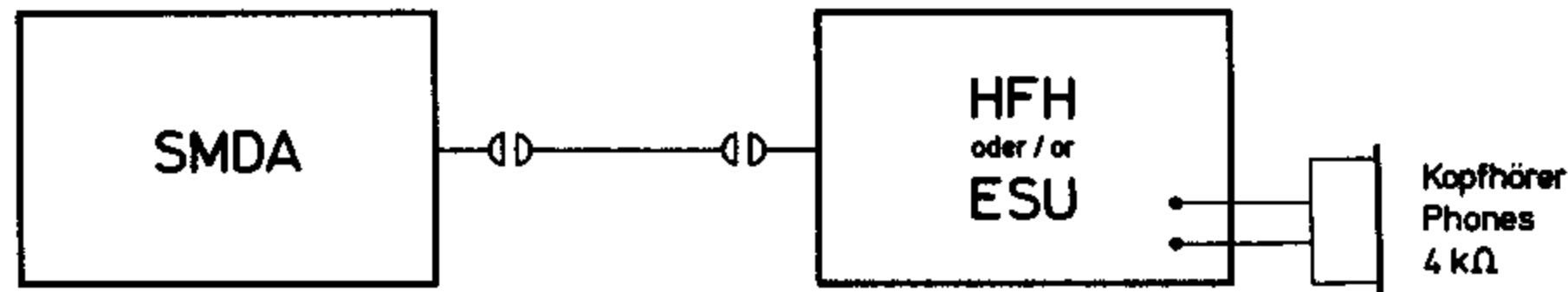

Fig. 3-3 Test setup for measurement of non-harmonic spurious waves

Measurement: Slowly tune the test receiver through its range at three frequencies of range I (upper limit, centre, lower limit) of the SMDA and measure the voltages whenever beats occur. The SMDA must be set for maximum output power. No non-harmonic spurious waves occur in the ranges II to VII; these ranges need not be measured.

Non-harmonic spurious waves: down from useful signal level 0.4 to 48 MHz > 70 dB; 35 to 48 MHz > 50 dB.

Adjustment: No adjustment is provided.

3.2.1.4 Measuring the Harmonics

Test setup



Fig. 3-4 Test setup for harmonics measurement

Measurement: Measure the amplitude of the first and second harmonics at two frequencies of each range (in the lower and the upper third of the range). The SMDA must be set for maximum output power.

Harmonics: (down from useful signal level, for output levels < 200 mV_{EMK}) 0.4 to 50 MHz > 26 dB, typical value > 30 dB; 50 to 484 MHz > 30 dB.

Adjustment: If harmonics appear in ranges II to VII, check the filter characteristic according to section 5.3.10.

3.2.1.5 Measuring the Residual FM (Deviation without modulation)

Test setup

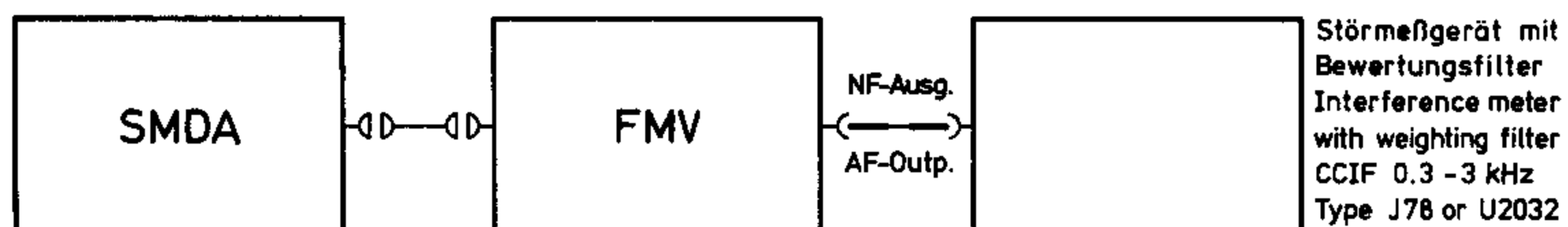

Fig. 3-5 Test setup for measurement of spurious FM

Measurement: Measure the residual FM at a medium frequency in each frequency range. The SMDA must be set for maximum output voltage. Measuring method: Tune the FMV to the frequency of the SMDA. Apply the AF voltage of the test output to the Interference Meter Type U2033 or Type J78 (with weighting filter according to CCIF 0.3 to 3 kHz). The test setup can be calibrated by means of the FM of the SMDA: deviation = 10 kHz, $f_{mod} = 1$ kHz. 10 Hz residual FM corresponds to $10 : 10,000 = 0.0001$ times the reading obtained with 10 kHz (ratio 60 dB). Take care to avoid changing the tuning indication or frequency deviation range of the FMV after calibration of the setup. The RF voltage check of the FMV must give a reading in the green range.

Permissible residual FM (weighted) < 10 Hz.

Adjustment: No adjustment is provided for residual FM. Range I is identical to range IV and need not be measured. (Check from 20 to 48 MHz.)

3.2.1.6 Measuring the Noise Voltage

Test setup

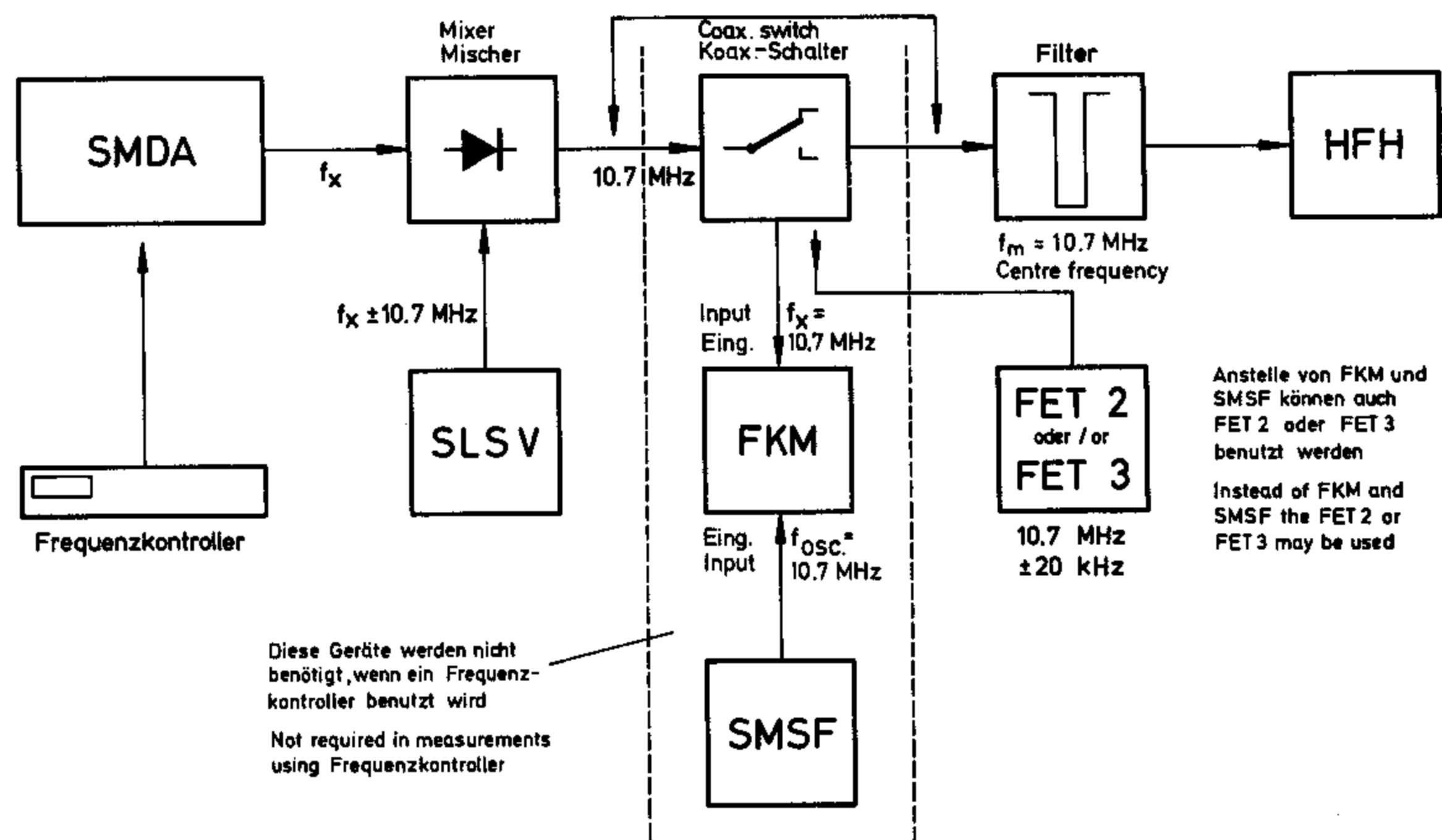

Fig. 3-6 Test setup for noise voltage measurement

Performance specifications of the equipment:

Mixer: Use a diode mixer with a very low noise level.

Signal source: S/N ratio must be at least 140 dB/Hz at 20 kHz from the carrier. The RF source must feature very good stability and low noise (if necessary, fed from AC supply stabilizer).

The VHF Signal Generator Type SLSV meets these requirements.

Coaxial switch: Cross-talk attenuation must be > 100 dB (disconnect FKM, if necessary).

Filter: Type F 2107-01 Marconi Manufacturing Company with matching network $Z = 60 \Omega$.

Bandwidth ± 6 kHz at midband frequency = 10.7 MHz (for channel spacing > 20 kHz). Attenuation > 110 dB at ± 12 kHz.

Test receiver (HFH): Frequency range depending on filter midband frequency (10.7 MHz for the above filter). Test bandwidth < 10 kHz. Sensitivity $0.1 \mu\text{V}$. Attenuator 100 dB.

Frequenzkontroller: The coaxial switch, the frequency indicator and the generator are not required when the Frequenzkontroller is used.

Measurement using Frequenzkontroller for tuning indication

- a) Set Field-Strength Meter Type HFH to 10.7 MHz.
- b) Adjust the VHF Signal Generator Type SLSV and the SMDA so that the mixture frequency is 10.7 MHz. Detune the SMDA and the HFH until the HFH reads maximum voltage. Adjust the level of the HFH to $+120$ dB referred to $0.1 \mu\text{V}$.
- c) Detune the SMDA by ± 10 kHz (indication on Frequenzkontroller). Check the deflection of the HFH. Correct the centre frequency on the SMDA according to b) until the deflection of the HFH is symmetrical to within ± 5 dB.
- d) Detune the SMDA by ± 20 kHz (indication on Frequenzkontroller). With a level adjustment according to b), the deflection of the HFH must not exceed 39 dB.

Using Frequency Indicator Type FKM and Stereo Signal Generator Type SMSF for tuning indication

- a) Adjust the Stereo Signal Generator Type SMSF and the Field-Strength Meter Type HFH to 10.7 MHz.
- b) Select the 500-kHz range on the Frequency Indicator Type FKM.
- c) Set the Coaxial Switch to FKM. Adjust the test frequency and maximum output voltage on the SMDA. Tune the SLSV so that the meter deflection of the FKM goes back to 0. Now set the coaxial switch to FILTER. Adjust the incremental tuning control of the SMDA and of the HFH for maximum indication on the HFH. Adjust the level to $+120$ dB referred to $0.1 \mu\text{V}$.
- d) Set the coaxial switch to FKM and adjust the SMSF for 0 deflection on the FKM.
- e) Change the coaxial switchover to FILTER and detune the SMDA by ± 10 kHz (indication on FKM); check deflection of HFH. Correct the centre frequency of the SMDA according to c) until the deflection of the HFH is symmetrical to within ± 5 dB.
- f) Set the coaxial switch to FILTER. Detune the SMDA by ± 20 kHz (indication on FKM). The meter deflection of the HFH must not exceed 39 dB if the level has been adjusted according to c).

The 100-MHz Counter Type FET 2 or the Frequency Counter Type FET 3, on which the IF and detuning by ± 20 kHz can be read, may be used in place of Types FKM and SMSF.

Calculation of noise/Hz bandwidth

Signal Level	120 dB
Noise level at 20 kHz from signal level	39 dB
Difference	81 dB
Conversion factor/Hz bandwidth	39 dB
at 8 kHz bandwidth ¹⁾	
S/N ratio	120 dB/Hz

¹⁾ At other bandwidths: conversion factor/Hz = $10 \log$ bandwidth

Minimum permissible S/N ratio: At 20 kHz from carrier 120 dB/Hz bandwidth.

Adjustment: Check performance of RF stages according to sections 5.3.4, 5.3.8 and 5.3.9.

3.2.2 Modulation Generator

3.2.2.1 Measuring the Frequency

Test setup

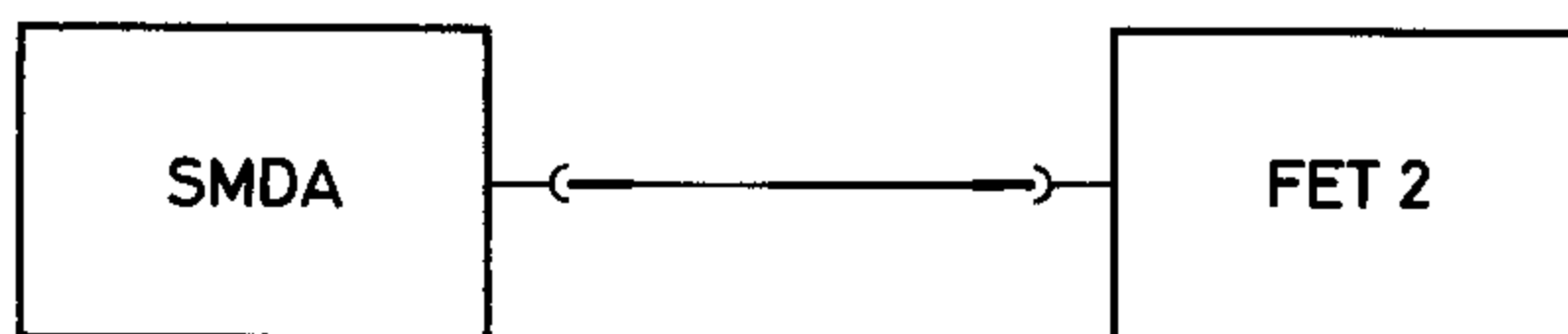

Fig. 3-7 Measurement of modulation-generator frequency

Measurement: Measure all fixed frequencies that can be selected with switch 8. In position "0.3 kHz", check the fine tuning adjustable with knob 10.

Permissible error: Fixed frequencies $\leq \pm 1.5\%$; Fine tuning $\pm (5\% + 5 \text{ Hz})$.

Adjustment: At uniform percentage deviations of the fixed frequencies adjust C3 on the modulation generator board 413141-6. If the adjustment range of C3 is insufficient, C4 (factory-adjusted) must be changed (see section 5.4.8). If deviations occur at the low generator frequencies (0.3 kHz and 0.4 kHz), adjust R141. A fine tuning error at -30 Hz can be corrected for by means of R144.

3.2.2.2 Measuring the Output Voltage

Test setup

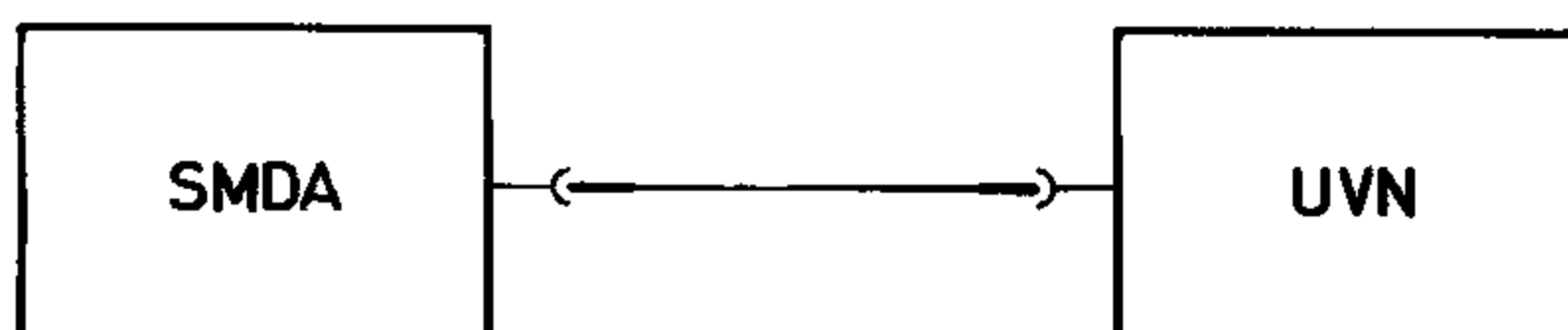

Fig. 3-8 Measurement of modulation-generator output voltage

Measurement: Measure the output voltage into 200 Ω at all selectable modulation frequencies.

Permissible error: see section 3.2.2.3. Adjustable in the range $< 0.5 \text{ mV}$ to 1 V.

Adjustment: No adjustment is provided.

3.2.2.3 Checking the Output-voltage Indication

For the test setup see section 3.2.2.2 Fig. 3-8. Set INDICATION switch to MOD. GEN.

Measurement: Compare the indication of meter 5 in the modulation unit with the indication of the Millivoltmeter Type UVN. Take measurements at the lowest and at the highest modulation frequency and in each range of indication (full-scale deflection).

Permissible error $< \pm (2\% + 1.5\% \text{ of FS})$

Adjustment: Adjust R36 on the meter circuit board 413141-7 in the modulation unit to the nominal value (see section 5.4.8).

3.2.2.4 Measuring the AF Distortion Factor

Test setup

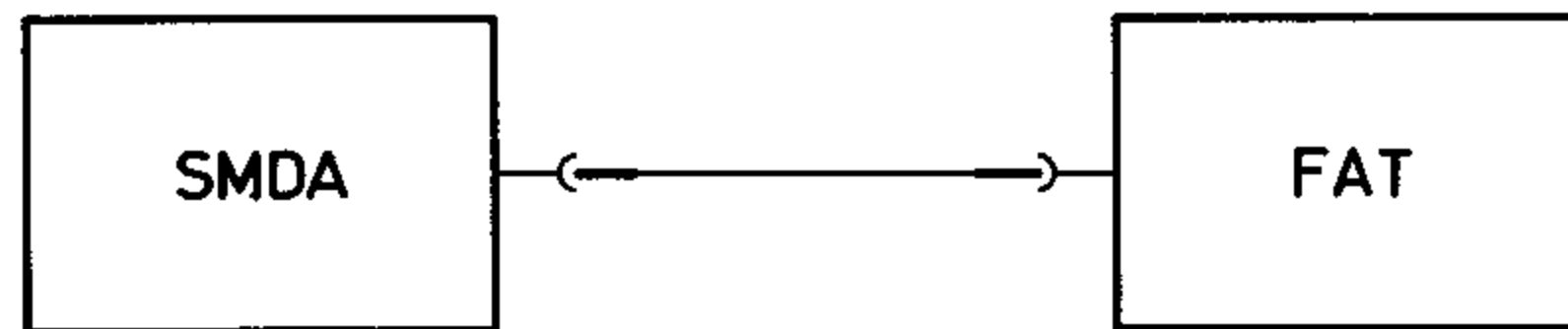

Fig. 3-9 Measurement of modulation-generator distortion

Measurements: Measure the maximum output voltage and its first, second and third harmonics into 200Ω at all modulation frequencies.

Evaluation: Amplitude of modulation frequency a , Amplitude of 1st harmonic a_1 , Amplitude of 2nd harmonic a_2 , Amplitude of 3rd harmonic a_3 .

$$\text{Distortion factor } d \approx \frac{\sqrt{a_1^2 + a_2^2 + a_3^2}}{a} 100 (\%)$$

Permissible error $< 1\%$

Adjustment: see section 5.3.8.

3.2.3 Modulation

3.2.3.1 Checking the Internal Amplitude Modulation

Test setup

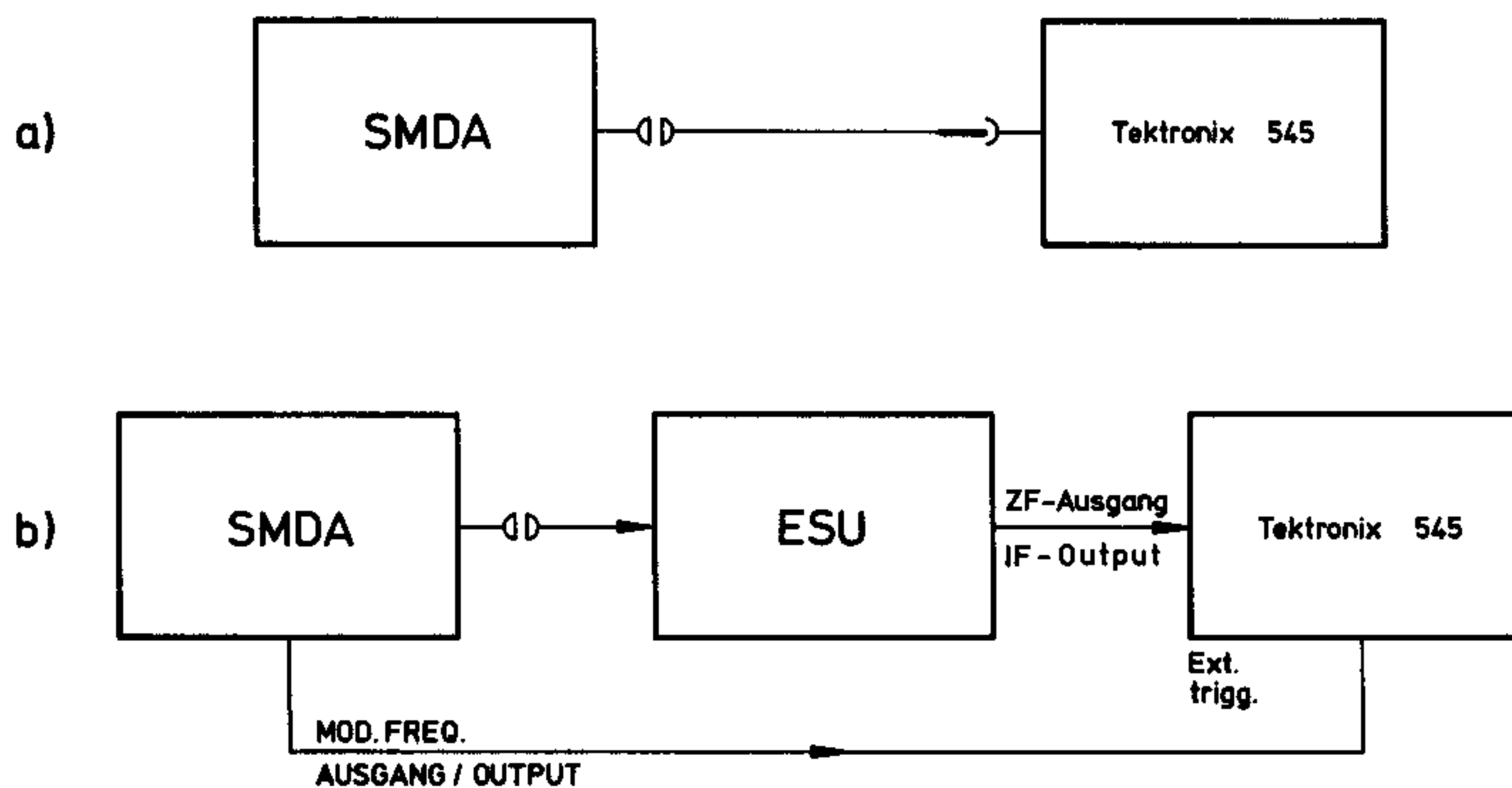

Fig. 3-10 Measurement of amplitude modulation
 a) up to 20 MHz, b) above 20 MHz

Measurement: Measure the modulation depth according to the following pattern:

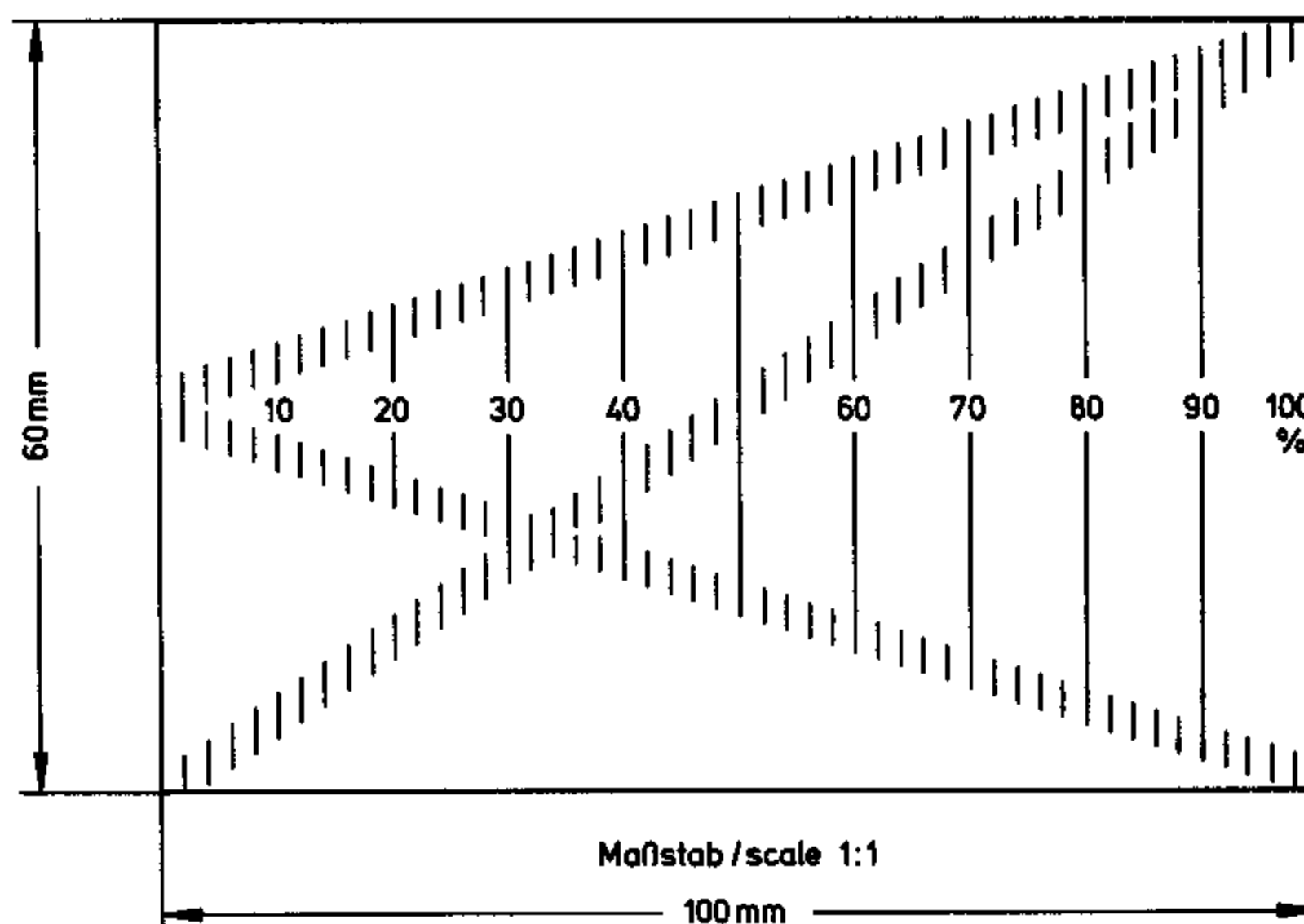

Fig. 3-11 Modulation depth read

Evaluation

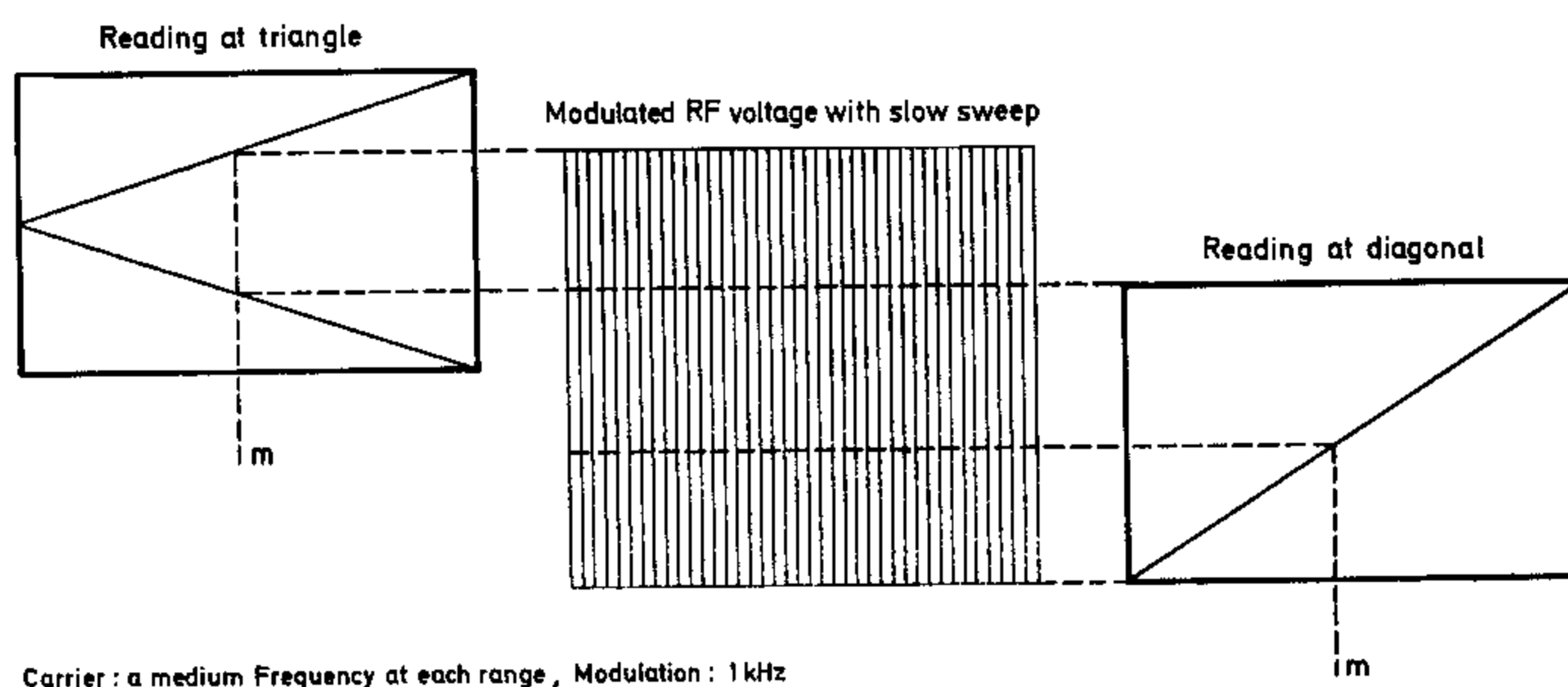

Fig. 3-12 Determination of the modulation depth

Permissible error: Permissible departure of modulation depth read on the pattern from the value adjusted on meter $5 \pm (3\% + 1.5\% \text{ of f.s.d.})$ valid up to $< 90\%$.

Example: 50% modulation; range of indication 100%;

$$\text{permissible error} = \frac{50 \times 3}{100} + \frac{100 \times 1.5}{100} = 3\% \text{ modulation depth}$$

The indication may therefore vary between a modulation depth of 47 and 53%.

Adjustment: see section 5.4.9.

3.2.3.2 Checking the External Amplitude Modulation

For the **test setup** see Fig. 3-10 section 3.2.3.1. Set the switch of the modulation unit to AM EXT., feed an AF voltage of 0 to $1.5 V_{\text{rms}}$, 1 kHz, to the AM EXT. socket.

Measurement: As described in section 3.2.3.1 for internal amplitude modulation, using modulation frequencies between 40 Hz and 4 kHz, 80 % modulation.

Permissible error: Voltage requirement for external modulation approx. 15 mV/% mod. Error of indication as in section 3.2.3.1.

Adjustment: No adjustment is provided.

3.2.3.3 Measuring the Spurious AM with Frequency Modulation

For the test setup see Fig. 3-10 section 3.2.3.1.

Measurement: As described in section 3.2.3.1. Adjust for a frequency deviation of 10 kHz with a modulation frequency of 1 kHz.

Permissible spurious AM $< 1 \%$

Adjustment: No adjustment is provided.

3.2.3.4 Measuring the Modulation Distortion with AM

Test setup

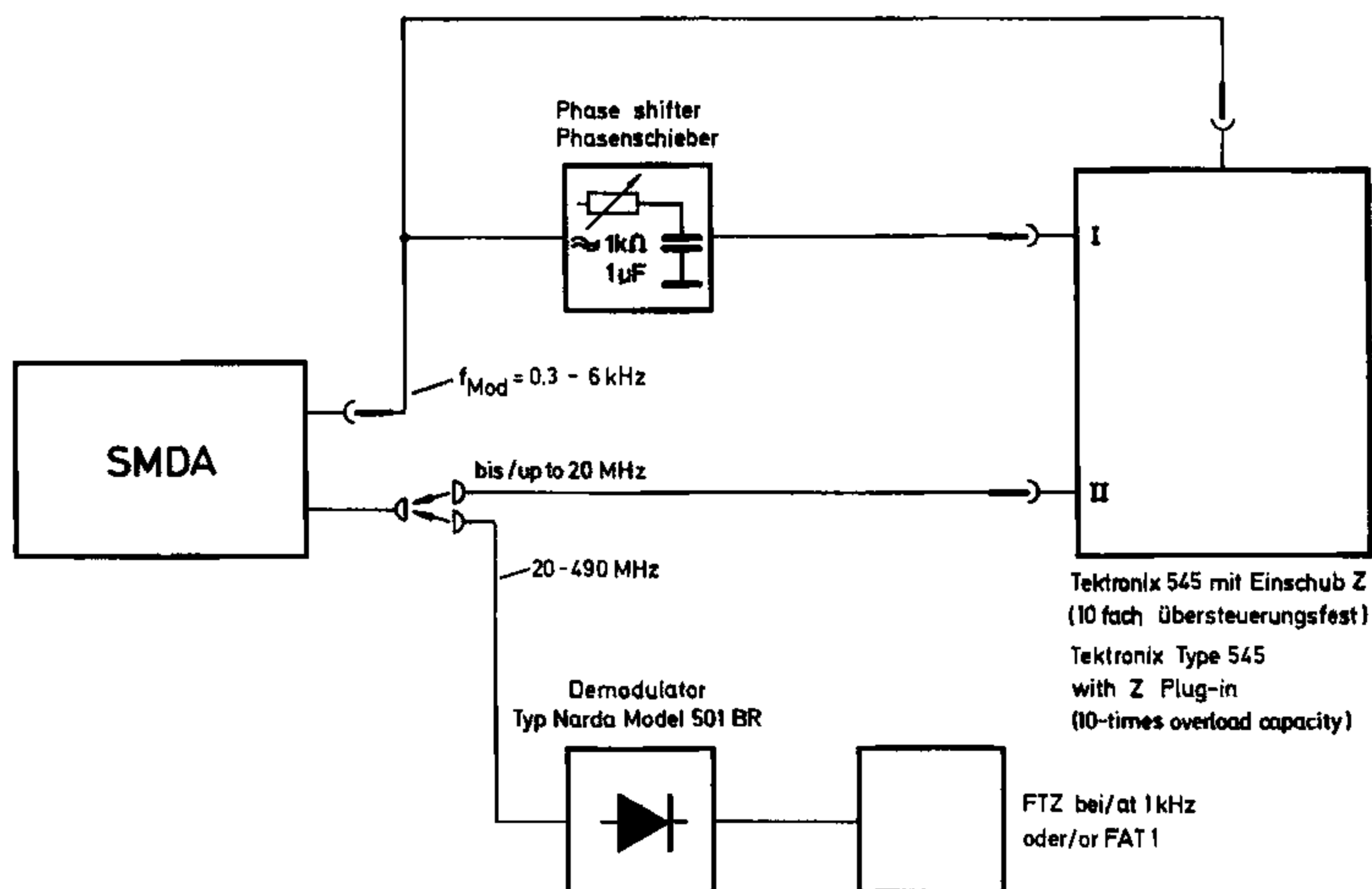
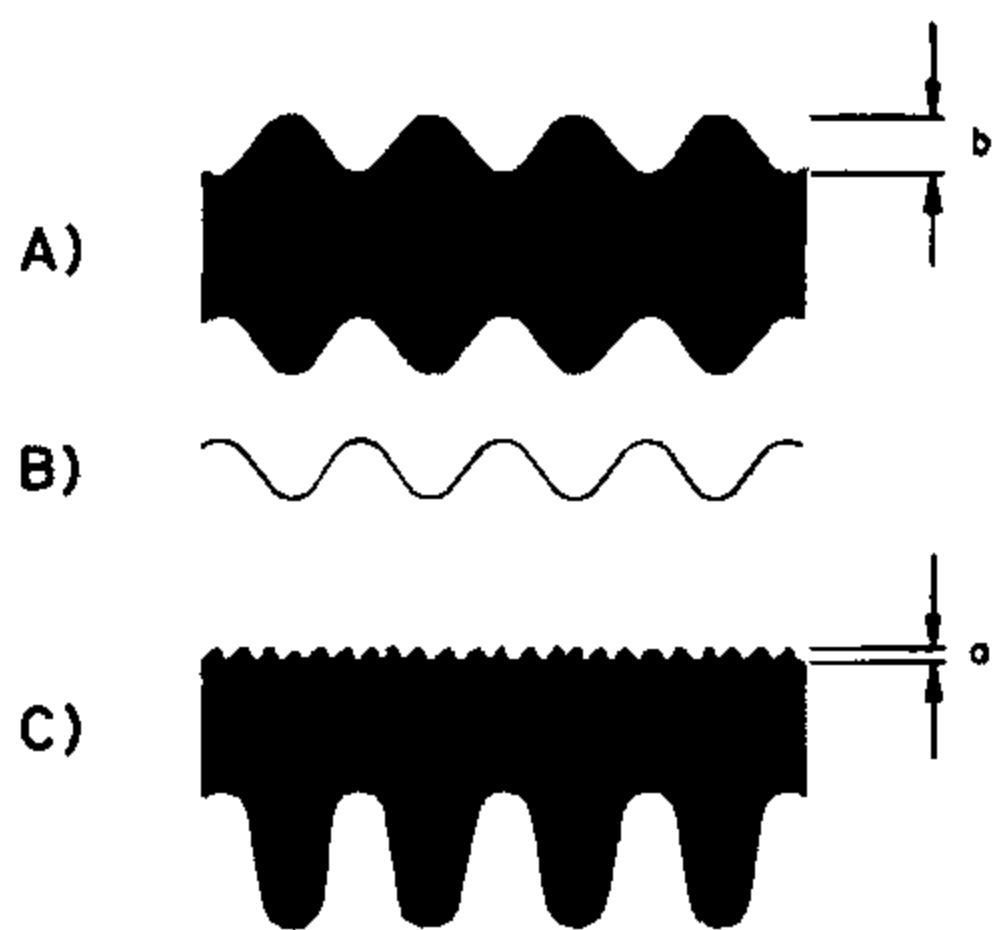

Fig. 3-13 Measurement of modulation distortion with AM

Measurement: Range I (0.4 to 20 MHz): Use an oscilloscope; no demodulator is required. Adjust the AF voltage and the phase so that the envelope of the carrier voltage is compensated for as far as possible.



$$\text{Evaluation: } d_m = \frac{a [V_{pp}]}{b [V_{pp}]} 100 \%$$

Fig. 3-14 Oscilloscopes

- A) Carrier voltage at oscilloscope input II
- B) AF voltage at oscilloscope input I
- C) Difference voltage = AF voltage carrier voltage
- a = residual ripple
- b = envelope

Adjust the carrier voltage of the envelope b and the AF voltage separately to about the same value. Form the difference of the voltages at inputs I and II. Adjust the AF amplitude for minimum residual ripple, correct the symmetry with the phase shifter, if necessary over-modulate the amplitudes by accurately known amounts.

Ranges I to VII (20 to 484 MHz): Tune the demodulator to the carrier signal, connect the Distortion Meter Type FTZ or the AF Wave Analyzer Type FTA to the AF output. Read distortion factor or harmonics.

Permissible distortion factor at 80 % modulation (40 Hz to 4 kHz) < 5 % (typical value 3 %).

Adjustment: see section 5.3.8.

3.2.3.5 Checking the Internal Frequency Modulation

Test setup (f = 20 to 484 MHz)

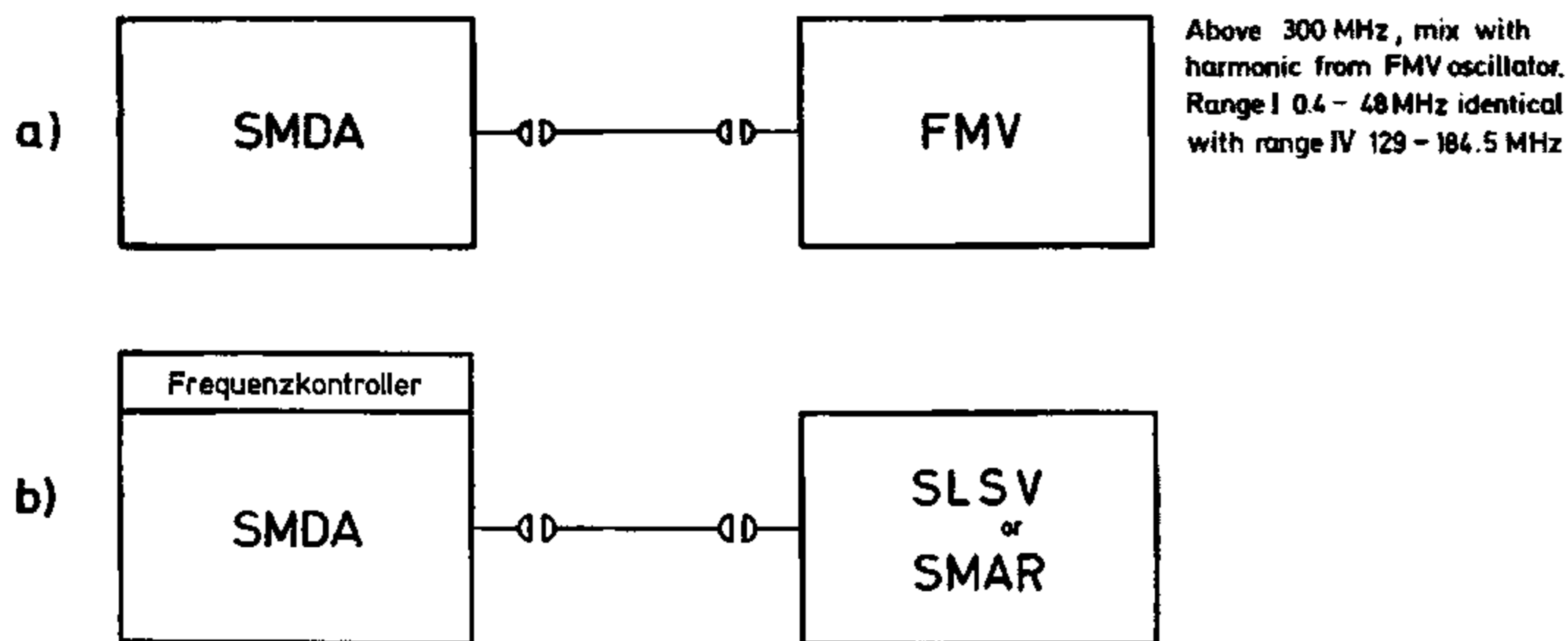

Fig. 3-15 Checking of internal FM und φM

a) using frequency deviation meter, b) using Frequenzkontroller

$f_{rec} = f_{gen} + f_{mix} =$ conversion to a frequency suitable for the frequency deviation meter

Measurement: According to Fig. 3-15 a):

Tune the frequency deviation meter and read the frequency deviation on the panel meter.

According to Fig. 3-15 b): Adjust the following controls:

SMDA: Output attenuator to $< 1\text{ W}$

Frequency deviation as for Fig. 3-15 a)

NOTE: Distortion measurement is possible only at 2 kHz modulation frequency.

Frequenzkontroller: Operation "+" or "-", adjust frequency deviation, range of frequency deviation indication 20 kHz.

SLSV: Adjust frequency to frequency of SMDA.

SMAR: Adjust level to 1.5 V into 50 Ω .

Take all measurements at least at 3 points of each frequency range (upper limit, centre and lower limit). Modulation frequency: preferably 1 kHz.

Permissible error: Permissible departure of measured frequency deviation from setting on meter $5 < \pm(5\% + 1.5\% \text{ of FS})^1$

Adjustment: If the departures vary in the direction (see section 5.4.8), adjust with R35 (in 413141-7 S). If the departures differ adjust the oscillator according to section 5.4.2. In case of uniform departures in one or several frequency ranges adjust the deviation network according to section 5.4.3.

3.2.3.6 Checking the External Frequency Modulation

For the test setup see Fig. 3-15 section 3.2.3.5.

Measurement: Take the measurement as described in section 3.2.3.5 but set the FM switch of the SMDA to EXT. and feed a modulation voltage to the FM EXT. socket. Voltage requirement for ext. modulation approx. 30 mV/kHz frequency deviation.

Permissible error: The permissible error of indication is the same as in section 3.2.3.5.

3.2.3.7 Measuring the Modulation Distortion with FM

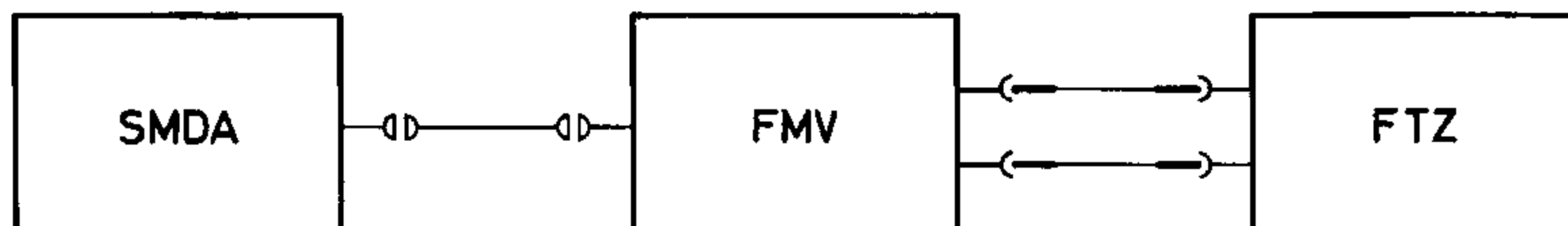

Fig. 3-16 Measurement of modulation distortion with FM and φM

Take measurements in the frequency ranges above 20 MHz. The values for the frequency range 129 to 184.5 MHz are valid also for the range 0.4 to 48 MHz. (Check in the range 20 to 48 MHz).

Measurement: Tune the Frequency Deviation Meter Type FMV to the frequency set on the SMDA; then the distortion can be read directly on the Distortion Meter Type FTZ. Take all measurements at the medium frequencies of each range. The frequency deviation is 4 kHz or 25 kHz at a modulation frequency of 1 kHz.

Permissible modulation distortion: at 4 kHz frequency deviation $< 1\%$, at 25 kHz frequency deviation $< 5\%$, at 75 kHz frequency deviation $< 10\%$.

Adjustment: No adjustment is provided.

¹⁾ Approx. 15 % from 401-420 MHz and from 470-484 MHz.

3.2.3.8 Checking the Phase Modulation

For checking the phase modulation proceed as for checking the frequency modulation (see sections 3.2.3.5 and 3.2.3.6) according to Fig. 3-15 at a modulation frequency of 1 kHz with $\Delta f/f_{\text{mod}}$ corresponding to the frequency deviation. Set switch $\varphi\text{M-FM}$ to position φM and the type-of-indication selector to $\varphi\text{M} [\Delta f/f_{\text{MOD}}]$.

3.2.3.9 Checking the Level Adjustment Frequency of the Phase Modulation

Measurement: Modulate the SMDA with a frequency of 1 kHz. Set switch $\varphi\text{M-FM}$ to position φM . Read the frequency deviation on meter 5.

Permissible error: $< 3\%$.

Adjustment: No adjustment is provided.

3.2.3.10 Checking the AF Response with Phase Modulation

The built-in modulation generator may be used for checking.

Measurement: Select the modulation frequency 0.3 kHz with switch 8. Set switch $\varphi\text{M-FM}$ to position φM and the type-of-indication selector to FM [kHz]. Adjust for a frequency deviation of 1 kHz and increase the modulation frequency with switch 8. The frequency deviation must increase with the frequency.

Permissible errors: up to 3 kHz – 3%, up to 5 kHz – 6%, up to 10 kHz – 30%.

Adjustment: No adjustment is provided.

3.2.3.11 Measuring the Modulation Distortion with φM

For the **test setup** see Fig. 3-16 section 3.2.3.7. Proceed as for FM, described in section 3.2.3.7.

Permissible modulation distortion: at 4 kHz frequency deviation $< 1\%$, at 25 kHz frequency deviation $< 5\%$, at 75 kHz frequency deviation $< 10\%$.

Adjustment: No adjustment is provided.

3.2.3.12 Checking the Response Threshold of the Maximum Frequency Deviation Indication

Measurement: Set switch $\varphi\text{M-FM}$ to position FM- or $\varphi\text{M-INT.}$, the type-of-indication selector to position FM [kHz] and switch 3 to position 100. Adjust for a modulation frequency of 1 kHz (switch 8). Increase the frequency deviation using knob 18 until lamp 21 lights up (78 kHz). The phase and the frequency modulation should have been checked beforehand. If this is not the case, the AF Millivoltmeter Type UVN may be used to measure the AF voltage ($2.5 V_{\text{rms}}$) at the socket Bu3.30 (413141-5 S).

Permissible errors: when measuring the frequency deviation +4 kHz; when measuring the AF voltage +0.2 V.

Adjustment: No adjustment is provided.

3.2.3.13 Checking the Automatic IF Generation

For the **test setup** see section 3.2.1.1. Feed a voltage of +14 V into the socket Bu7R on the rear wall of the SMDA via a 82-k Ω resistance.

Measurement: Vary the signal generator frequency at the beginning, in the middle and at the end of each frequency range by cutting the DC voltage present at socket Bu7R into circuit and out of circuit. The frequency difference should be approximately 110 kHz.

Permissible error: ± 12 kHz.

Adjustment: In the case of one-sided deviations, adjust with R150 (in 413141-5 S).

3.2.4 Measuring the Voltage at RF Output II

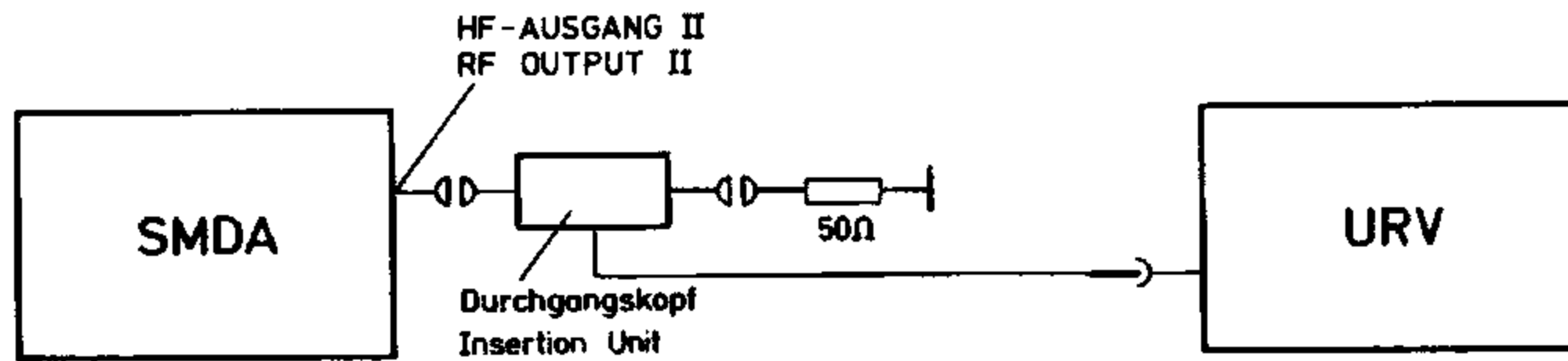

Fig. 3-17 Voltage measurement at RF OUTPUT II

Measurement: Measure at one point in each frequency range. Output voltage 15 to 75 mV_{rms}.

Adjustment: see section 5.3.7.

3.2.5 Measuring the RF Distortion Factor

The RF distortion factor must be measured with a sampling oscilloscope (Tektronix Type 1S1) at RF output II.

Permissible distortion factor: ≤ 10 %. In particular, no additional zero passages must occur.

3.2.6 Measuring the Frequency Deviation in Sweep Operation

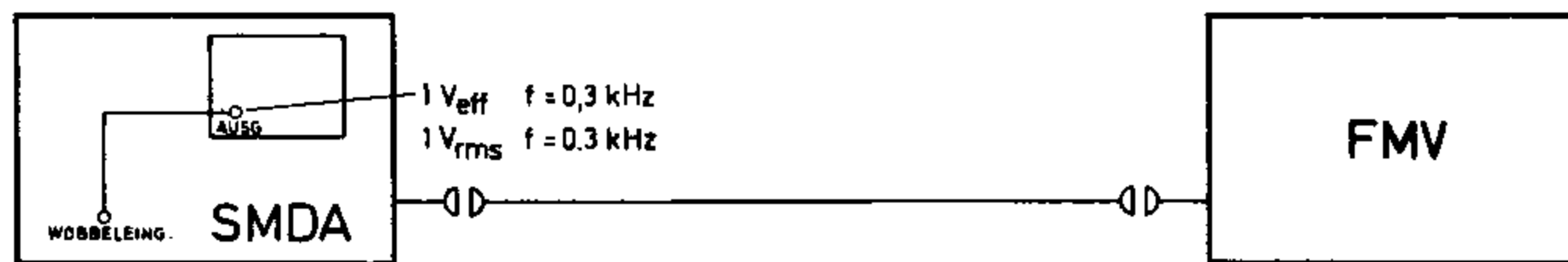

Fig. 3-18 Frequency-deviation measurement in swept-frequency operation

Measurement: Measure at one point in each frequency range.

Range	Frequency deviation at 1 V _{rms}
I	4.8 kHz
II	19 kHz
III	38 kHz
IV	38 kHz
V	76 kHz
VI	76 kHz
VII	79 kHz

} ± 15 %

Table 3 Measuring the frequency deviation in sweep operation

Adjustment: See section 5.4.2 Deviation (with DC) measured via synchronization input.

3.2.7. Measuring the RF Leakage

The RF leakage of the SMDA has been minimized to such an extent that at a distance of approximately 0.5 m the field strength is less than 1 μV. Since the field strength decreases with the third power of the distance, signals can, however, be received with a selective antenna at 5 cm from the instrument. For the measurement, a receiver for 400 MHz with a sensitivity of > 1 μV_{EMF} is required for 6 dB signal-to-noise ratio.

3.2.7.1 Determination of the Receiver Sensitivity

Test setup

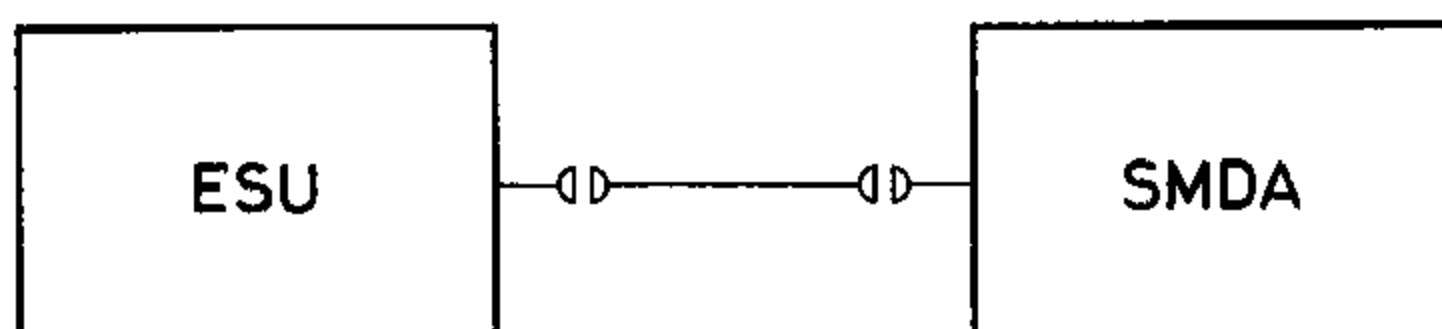

Fig. 3-19 Measuring of the Receiver Sensitivity

Measurement: In all measurements make sure that the cables exhibit no RF leakage and that the contact resistances are kept to a minimum.

Adjust the following controls on the SMDA: Attenuator to -130 dBV, Switch FM to INT., Switch 3 to 4 kHz frequency deviation, Switch 8 to $f_{mod} = 1$ kHz and Switch AM to UNMOD. Adjust the receiver as follows: Select maximum sensitivity, Turn the control CALIBRATION II fully clockwise, select a bandwidth of 12.5 kHz, use average-responsive indication, operate without AFC and note noise deflection.

Advance the attenuator control on the SMDA until the deflection on the receiver has increased by 6 dB. The 6-dB value must be below 1 μV_{EMF}. Then advance the attenuator control on the SMDA further until 1 μV_{EMF} is reached. The corresponding indication on the receiver serves as a point of reference for all other measurements and should be noted down.

3.2.7.2 Measuring the RF Leakage

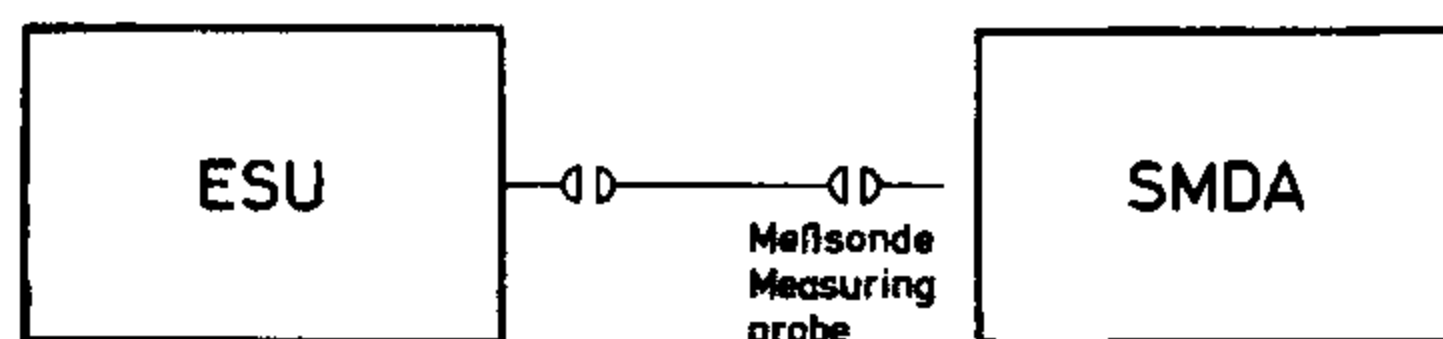

Fig. 3-20 Measuring of RF Leakage

Measurement: Test frequency: 450–470 MHz. The measuring probe should be 16 cm long (length of copper wire at the end of a cable). Allow the receiver and the SMDA to warm up. Make the adjustments according to section 3.2.7.1. Connect the measuring probe and tune the receiver to the frequency of the signal generator. For this purpose, the antenna should be placed near the output socket of the SMDA and the attenuator of the SMDA be set to approximately 1 V_{EMF}. Then short-circuit the RF OUTPUT II of the SMDA and set the attenuator of the SMDA to –130 dBV. At the attenuator setting 1 V_{EMF}, greater unwanted radiation occurs but this is of no consequence in practical applications since high protection against leakage is required only when adjusting very small output voltages. Now find the maximum field strength at a distance of approximately 5 cm from the SMDA, using the measuring probe.

Test result: A deflection of 8 dB above the reference value is permissible. If a higher level is measured (from approximately 6 dB above the nominal level), first check the connecting cables for leakage. Particular attention should be paid to the cables K8 and K9. If all cables are properly assembled and connected to chassis and there is still leakage, remove the cable K1 from the amplifier and shield the cable end. If this does not stop leakage either, unscrew the cover of the oscillator and clean it. Then check the neoprene padding for sufficient pressure and thickness (minimum thickness 2 mm with foil). If necessary, replace the cover (41314-2.40). Clean the cover and the casing prior to reassembly with trichlorethylene or alcohol. If the oscillator is RF tight, replace the cable K1, loosen cable K8 and provide socket Bu19 with an earthed shield. If the SMDA still exhibits leakage, unscrew the two amplifier covers. The foils must not be damaged. New covers can be ordered under the Stock Nos. 41314-5.7 and 41314-5.8. The covers and the edges of the amplifier chassis must be cleaned with trichlorethylene or alcohol. If necessary, a second washer may be used with the screws. Check the cables K8, K9 and K10 for proper connection to chassis and screw down tightly.

3.2.8 Checking the Output Voltage on the VOR-ILS Unit

Measurement: With the VOR-ILS Unit connected, connect the Multimeter UGWD between chassis and contact 1 of socket 31 VOR-ILS ADAPTER. Set output attenuator 13 to -10 dB. The output voltage at Bu31/1 should be 0 V at 115 MHz.

Permissible error: ± 20 mV

Adjustment: The voltage can be adjusted to 0 V using R276 in the AGC amplifier 41314-3.10.7; see also 5.4.4.

3.3 Mechanical Maintenance

3.3.1 Cleaning

Cabinet: Wipe the cabinet with a dry non-fuzzy cloth.

Front panel: Remove the panel controls (see section 4.19.1) and clean the front panel with a cloth moistened with alcohol. Do not use polish or any solvents. Do not disengage the tuning drive.

Interior: Withdraw the chassis from the cabinet according to section 3.3.2 and clean with compressed air and a soft brush.

3.3.2 Withdrawing the Chassis from the Cabinet

Loosen the four Phillips-type screws which are accessible through the bore holes in the carrying handles. Then the chassis can be withdrawn from the cabinet. NOTE: Pull out the power plug before withdrawing the chassis from the cabinet. If the SMDA is operated without its cabinet, parts carrying AC supply voltage are accessible. The safety rules regarding work on live equipment must be observed.

4. Circuit Description

(see circuit diagrams 41314 S Bl.1, Bl.2, Bl.3, 413141 S and level diagram).

4.1 Oscillator and Frequency Modulator (circuit diagram 41314 S Bl.1 and Fig. 4-7)

Two stators are electrodeposited on the ceramic segments of printed-circuit design which form the oscillators and frequency modulators BN 41314-2 (Fig. 4-7). All stators are tuned by a common rotor. Each segment consists of a complete oscillator with a frequency modulator. The outputs of all oscillators are combined via a star-connected resistance network (R801 to R806). The oscillator in use is fed with the DC voltage cut in via the associated switch (S16 to S22). The rotor is capacitively earthed via the ganged cylindrical capacitor C835. Electronic tuning and switching of the oscillators and optimum design of each individual oscillator are thus possible. The varactors G1360 to G1410 provide the frequency modulation. Frequency-dependent coupling of the varactors via the second stator coating C835I to C835XII of the oscillator enables a constant deviation independent of the frequency. Suitable stator coating in each frequency range ensures linear frequency variation and constant deviation. The varactors are fed via the feed-through capacitors C800 to C805 with the DC and AC voltages required for frequency modulation and synchronization with the Frequenzkontroller 100.4542.

4.2 FM Chokes (circuit diagram 41314 S Bl.1 and Fig. 4-1)

The modulation voltage is fed to the parallel-connected diodes G1360 to G1410 via the FM chokes 41311-2.95, 41311-2.96, 41311-2.97 and the emitter follower T42. The temperature coefficient of transistor T42 compensates for that of the varactors. The transistor is therefore located in the same cast housing as the oscillators.

4.3 Deviation Network (circuit diagram 41314 S Bl.1 and Fig. 4-5)

The circuit board of the deviation network 41314-2.100.25 also carries the switches I to VII for the selection of the appropriate oscillator and the transistors T47 and T48 forming a temperature-compensated amplifier. The SYNCHRONIZATION input Bu6 permits the synchronization voltage from the Frequenzkontroller. The control voltage is weighted according to the frequency range by the voltage divider R491 to R497 and R484 to R490 in order to keep the loop gain constant with range-dependent division ratios in the case of synchronization. Consequently, the sweep width also differs in the different ranges. The other input of the amplifier is controlled by the frequency modulation voltage of the modulation unit 413141. By connection of the corresponding voltage dividers R459 to R464 and R466 to R471, the modulation voltage has the same frequency deviation in all ranges.

4.4 Buffer (circuit diagram 41314 S Bl.2 and Fig. 4-1)

The buffer 41311-5.10 is composed of two stages. It reduces shifts of the oscillator frequency due to the AGC circuit and the amplitude modulator to a minimum. RC sections adequately flatten the amplitude/frequency response, like in many of the following stages.

4.5 AGC Circuit (circuit diagram 41313 S Bl.2 and Fig. 4-1)

The AGC circuit is combined with the buffer on circuit board 41311-5.10. The two parallel-connected PIN diodes G110 and G111 act as variable operating resistance of the transistor T3.

They are connected in parallel with the DC feed-in via R56, L30, the cathodes of the two diodes being connected to the collector of the transistor T3 via the disc capacitors C32 and C33 and the anodes directly to chassis. The AGC voltage is applied to the PIN diodes via T5, T6, L40, L50, R63 and R64. The Zener diodes G112 and G113 limit the transient response. The transistors T4 and T31 furnish the low-impedance reference level for T6 via R60.

4.6 Frequency Converter (circuit diagram 41314 S Bl.2)

The output frequency in range I is produced by frequency conversion; in the other ranges, the RF voltage is applied directly to the amplitude modulator and, in parallel via a buffer, to the second output.

4.7 Low-pass Filter Preceding the Mixer (circuit diagram 41314 S Bl.2 and Fig. 4-1)

The low-pass filter 41314-5.11/2 suppresses the harmonics of the oscillator so that together with the signal coming from the crystal oscillator an output frequency with low content of harmonics and non-harmonic spurious frequencies is produced. The two reed relays Rs1, Rs2 of the filter switch the mixer in the lowest frequency range.

4.8 Mixer (circuit diagram 41314 S Bl.2 and Fig. 4-1)

The mixer 41314-5.12 contains the diodes G180 and G181. Thanks to its balanced design, it suppresses a large part of the non-harmonic spurious waves. Maximum suppression of the crystal-oscillator voltage is adjusted with C89. In the frequency range 0.4 to 48 MHz, the mixer also serves as beat indicator at the output frequency "0" and is thus used for the calibration of the frequency scale. The amplifier T7 and T8 amplifies the beat voltage and the diodes G170 and G171 serve for rectification. The DC voltage is indicated on meter 29 (Fig. 2-1).

4.9 Low-pass Filter Following the Mixer (circuit diagram 41314 S Bl.2 and Fig. 4-1)

The low-pass filter 41314-5.14/2 suppresses harmonics and high-frequency non-harmonic spurious waves of the mixer. The filter contains a broadband amplifier (T50, T51), which adjusts the level of the mixer output voltage to that of the voltage driving the amplitude modulation stage in the other ranges directly without passing through the mixer. The two reed relays Rs3 and Rs4 switch the mixer in the lowest frequency range.

4.10 Crystal Stage (circuit diagram 41314 S Bl.2 and Figs. 4-3 and 4-4)

The crystal stage 41313-9.5 comprises the crystal-controlled oscillator (T43) and the tuned amplifier (T44). It is connected to the mixer with the solid-jacket cable K3. In the frequency ranges II to VII where the crystal stage is not used, it is disconnected by interruption of the operating voltage.

4.11 Second-output Amplifier (circuit diagram 41314 S Bl.2 and Fig. 4-1)

The amplifier for the second output is on the modulator circuit board 41314-5.15/2. It consists of transistor T10. A voltage independent of the output attenuator and having the

frequency adjusted on the SMDA is available at RF OUTPUT II at the rear of the set for the connection of the Frequenzkontroller. At RF OUTPUT II the externally applied voltage can also be measured (see section 3.2.4).

4.12 Modulator (circuit diagram 41314 S Bl.1 and Fig. 4-1)

The modulator 41314-5.15/2 operates with current distribution, the DC voltage produced in transistor T15 being impressed on the two modulation transistors T16 and T17 via R140. The RF energy amplified in transistor T11 is applied to the emitters of T16 and T17. It is according to the base control either taken to chassis via C141, C142, R151 or coupled out via C147. The signal is boosted by approximately 12 dB in transistors T18, T19. The AF voltage passes via cable K6, the AM filter and the transistor T9 to the differential amplifier T13, T14. It is pre-emphasized in the two diodes G150, G151 and controls the bases of the RF modulation transistors T16 and T17 in opposite phase. Furthermore, a feedback voltage corresponding to the VOR-ILS output voltage is applied to the collector of T9 via cable K5 and R149, which is derived from the rectified voltage of the AGC amplifier. This greatly reduces the AF modulation distortion.

4.13 Output Stage and Output Filter (circuit diagram 41314 S Bl.2, Fig. 4-1)

The output stage 41314-5.21/2 consists of two stages and delivers an output level of 0.5 V into 50 Ω . With the attenuator pad R210 the RF level can be adjusted within the amplifier chain such that the RF level at the collector of T11 is 60 to 70 mV and at the RF OUTPUT II 15 to 20 mV (at an attenuator position of approx. -20 dB), see also section 5.3.7. The output filters 41314-5.22 are switched for the different frequency ranges by the reed relay contacts of Rs5 to Rs14; they are designed as Cauer filters. The low-pass filters suppress harmonics in the output voltage. The resulting low distortion is important not only for the application of the SMDA but also for the correct rectification of the output voltage with G1260 (in the attenuator 41314-3). This ensures a flat frequency response of the AGC circuit and a constant feedback which effectively reduces the modulation distortion. By short-circuiting the sockets Bu14.4 and Bu14.5, the transistor T32 (on 41313-17.3) cuts off the operating voltage of the driver and of the output stage (carrier suppression). By short-circuiting the sockets Bu14.4 and Bu14.5, the transistor T32 (on 41313-17.3) cuts off the operating voltage of the output stage and the modulation generator (carrier suppression).

4.14 Attenuator (circuit diagram 41314 S Bl.2 and Figs. 4-1 and 4-2)

The attenuator 41314-3 has an exponential attenuation characteristic. It consists of potentiometer R260 whose resistance film is earthed at both broadsides by means of metallized strips. The wiper is moved by a spindle-controlled slider to which the pointer for level indication is fixed.

4.15 Overload Protector (circuit diagram 41311-7 S and Fig. 4-2)

The overload protector 41311-7 protects the output stage of the SMDA, the AGC amplifier and the attenuator from RF or DC voltages inadvertently fed to the RF OUTPUT 16. The overload protector interrupts the lead K9 between the output socket and the attenuator within a millisecond by means of the reed contact 1. The overload protector comprises a capacitive voltage divider C4, C5 whose output voltage is rectified by the temperature-

compensated diode G12 and then interrupts the current through the relay coil Rs1 via the amplifier T1 to T4. Thus the connection between the output socket and the attenuator is interrupted also when the SMDA is switched off (important for checking purposes). If DC voltages above about 1 V are applied to the output, the overload relay responds via R14, R9, G16 and G14. When the output is cut off, the multivibrator T7, T8 is put into operation. It controls the incandescent lamp, which blinks, via transistor T9 and cancels the effect of the positive feedback provided by T1, G15, G16, via transistor T5. As a result, the overload protector is connected through again when no RF or DC voltage is present. If RF power is fed to the RF OUTPUT 16, the pilot lamp lights or blinks.

4.16 AGC Amplifier (circuit diagram 41314 S Bl.2 and Fig. 4-1)

The AGC amplifier 41314-3.10.7 produces the rectified voltage for the automatic level control of the SMDA and the modulation feedback. G1260 in the attenuator 41314-3 serves as the rectifier diode; it is biased, for linearization of the characteristic and for temperature compensation, with the forward voltage at G1261 of the current through R274. The rectified voltage is amplified in the differential amplifier T261-II and DC coupled via R290, D15 to the AGC circuit 41311-5.10. The rectified voltage is derived at the emitters of the transistors T261-II and after multiplication by a factor of 10 in the high-impedance operational amplifier B1 is taken to the filters 41313-17.1 and 41313-17.2 by means of K18. It is then available at socket Bu14.1 for use in the VOR-ILS Unit as is the demodulated AF voltage in AM operation after having been multiplied by a factor of 10.

4.17 Modulation Unit (circuit diagrams 413141 S, 413141-5 S, 413141-6 S and 413141-7 S as well as Figs. 4-2 and 4-3)

The modulation unit consists of three printed circuit boards which are interconnected by means of plugs and sockets. On the basic circuit board the modulation voltage is processed. The other two circuit boards contain the modulation generator and the meter amplifier.

Modulation Voltage Processing (413141-5 S)

The desired type of modulation (phase, frequency or amplitude modulation) may be selected with the switches S100 or S200, respectively. The corresponding potentiometers R100 and R200 are used for adjusting the modulation index, frequency deviation or modulation depth. In the case of phase and frequency modulation, the AF signal passes via the FET T110 to the emitter follower B120. With frequency modulation, this signal is applied directly via the switch S200III to the frequency deviation network of the basic unit, to the maximum frequency deviation indication and to the meter amplifier. With phase modulation, the frequency-dependent voltage divider C130, L130, R130 and the amplifier B130 are interconnected. To minimize the noise voltage at the output of B130, the gain must be kept low which calls for an RC section with a low limit frequency and, consequently, low voltage attenuation. Since this RC section does not, however, supply a linearly increasing AF voltage, the inductance L130 has been provided for compensation.

When measuring the frequency deviation with the Frequenzkontroller, a positive voltage is applied to the base of the transistors T153 and T113 via Bu1.11. This cuts off the FET T110 whereas T111 becomes conductive via T112. In this way, any AF voltage which may effect the frequency deviation measurement is safely switched off. Moreover, transistor T152 is made conductive. As a result, a negative voltage tapped from the voltage divider R150, R151 and R152 is applied to the frequency deviation network of the basic unit a low impedance via the transistors T150 and T151 and Bu1.8 and Bu1.14 so that the oscillator is

about 110 kHz off-tune. With amplitude modulation, the AF voltage passes from the potentiometer R200 via R202 and Bu1.2 to the amplitude modulator. The rectified voltage supplied by the AGC diode G1260 in the attenuator 41314-3 is used for the indication of the AM. The two Zener diodes G1201 and G1202 protect the AM modulator against overvoltage in the case of external modulation.

Modulation Generator (413141-6 S)

The modulation generator is an RC oscillator. The 12 fixed frequencies are tapped from the resistor chain R101 to R111 and R121 to R131 of the Wien bridge by means of switch S1. To make the generator frequencies as independent of temperature as possible metal-film resistors have been used whereas the corresponding bridge capacitances are provided by mica capacitors. The fine tuning of the generator frequency is accomplished with the twin potentiometer R1 in 413141 S. The thermistor R12 which is connected into the feedback path of the generator keeps the amplitude constant. Since, however, this amplitude is temperature-dependent on account of the thermistor, the amplifier B2 is connected in series whose gain, in turn, is temperature-dependent through the thermistor R22, compensating for the amplitude temperature response. The connection from R11 to chassis is established via the type-of-modulation selectors (S100 and S200 in 413141-5 S). If both switches are in the position EXT., this connection is separated and the modulation generator stops operating. After amplification in B2, the modulation generator voltage is applied to the circuit board for modulation voltage processing. An emitter follower (T1) is connected in series to the generator output (Bu1 in 413141 S), whose output voltage can be adjusted with the potentiometer R26 (knob 7).

Meter Amplifier (413141-7 S)

On the meter panel the indication mode switch S1 is located, which in position MOD. GEN. switches off the charging capacitor (average-responsive rectification). These switch is followed by a precision voltage divider R10 to R14 from which a voltage is tapped by means of switch S2 according to the selected indicating range and applied to the amplifier B1. The rectification is effected by the diode G12 which is connected to the output of the high-speed operational amplifier B2. Since the feedback voltage is tapped after the diode, a completely linear rectification is ensured, the bend of the diode characteristic being less by the amplification factor ($> 10,000$). The voltage passes via the series resistor R33 and the type-of-indication selector S1111 through one of the trimmers R34, R35, R36 or R37, depending on the position of the type-of-indication selector, to the panel meter J1 in 413141 S. In order to achieve a small error of rectification even with frequencies of 30 Hz, the charging capacitor had to be selected such that the pointer of the meter would stabilize only after approx. 10 sec. To avoid this, a discharge circuit consisting of G13, R31, C33 and T1 has been incorporated which after a delay of $t \approx 40$ msec ($t > T_{30\text{Hz}}$) ensures a rapid discharge. The discharge time is considerably less than the response time of the panel meter.

4.18 Power Supply (circuit diagram 41314 S Bl.3 and Figs. 4-4 and 4-6)

The power supply consists of the circuit board 41311-4.5 comprising the transformer and the capacitors and of the circuit boards 41311-4.7 and 41314-4.9. The regulators of the "+" and "-" power supplies and the temperature-compensated reference Zener diodes are located on the lower circuit board 41311-4.7 because of the negligible heat development. The series transistors T57, T59 with the drivers T58, T60 and rectifiers G1570, G1590, which develop appreciable heat, are located on the upper circuit board 41314-4.9. The power supply is designed for extremely low hum voltages, high stability and small temperature effect.

4.19 Mechanical Construction

4.19.1 Removing the Operating Controls

Designation	Ref. No. in Fig. 2-1	Remarks
Coarse tuning drive	24	Hex socket-head screw SW 2
Fine tuning drive	23	Remove knob of coarse drive. Loosen the grub screw in the flange of the knob (parallel to the shaft). Remove knob by turning it anticlockwise
RF output attenuator	12, 13	Hex socket-head screw SW 2

Table 4 Removing the Operating controls

4.19.2 Withdrawing the Modulation Unit (Fig. 4.2)

After pulling out the cable plug St1 and loosening the four Phillips-type screws in the corners of the front panel of the modulation unit, the latter may be withdrawn from the SMDA.

4.19.3 Opening the Oscillator and Replacing the Oscillator Segments (Figs. 4-2, 4-3, 4-7 and 4-8)

Withdraw the signal generator from the cabinet as described in section 3.3.2. Remove the cover of the oscillator after loosening 12 screws (M 3 x 6 DIN 84). Find the location of the segment to be replaced according to the following drawing:

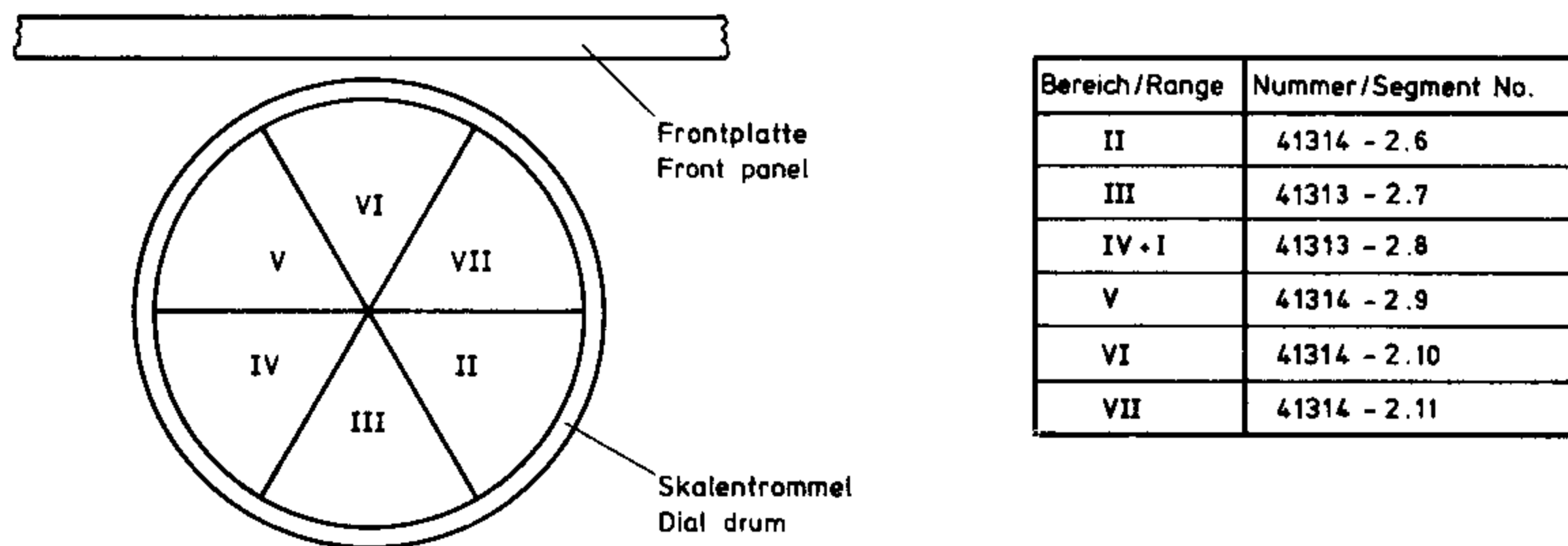

Fig. 4-8 Location of the segments

Remove the segment concerned by proceeding as follows: Adjust the tuning knobs so that the segment concerned is not covered by the rotor plate of the variable capacitor. Disconnect or unsolder the leads of the -18-V operating voltage, of the deviation voltage and of the RF output in range II. Loosen five screws (M 2 x 6 and M 2 x 8 DIN 84); take care that the washers do not drop into the oscillator. The oscillator segment can now be taken out. Remove also the guide sleeves from the segment. Inserting the new oscillator segment: Put both guide sleeves into the inner mounting holes of the segment. Before inserting the segment, its contact faces must be cleaned with trichlorethylene.

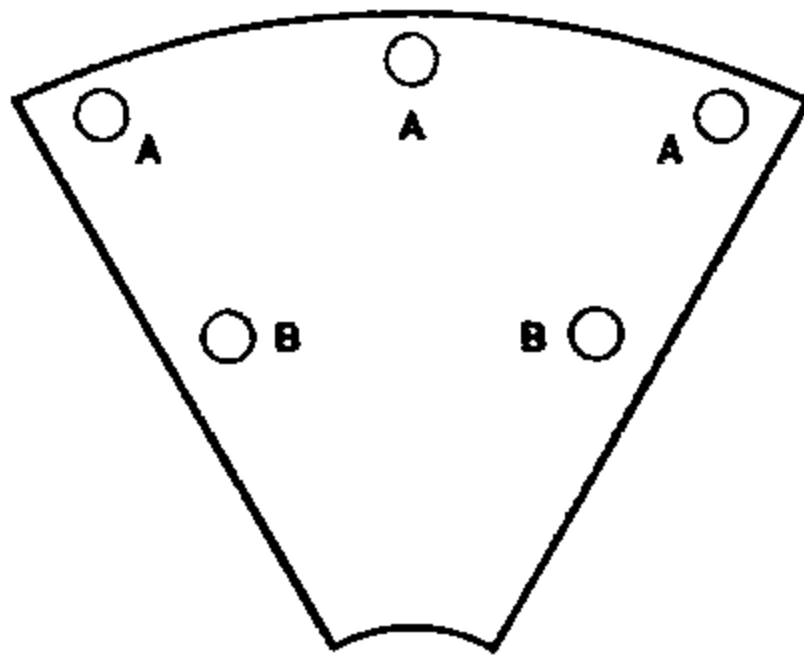

Fig. 4-9 Location of the Mounting holes

- A) Mounting holes
- B) Mounting holes with guide sleeves

Insert the oscillator segment in such a way that the two guide sleeves engage in the respective slots. To fix and connect the segment proceed in the reverse order as for withdrawing. Next adjust the corresponding oscillator range (see section 5.4.2). Before reassembling, clean the contact faces of the cover and of the case with trichlorethylene. Then place the cover on the oscillator. Make sure that the adjustment holes are in the proper position. The signal generator can now be put back into its cabinet. Check the performance in the range concerned according to section 5.3.2.

4.19.4 Withdrawing the RF Attenuator and the AGC Amplifier (Fig. 4-2)

Withdraw the signal generator from its cabinet as described in section 3.3.2. Remove the knob of the RF attenuator (see section 4.19.1). Disconnect or unsolder the leads K2, K5, K8, K9, K18 (in 41314 S Bl.2) and the +18-V and -18-V leads (in 41314 S Bl.3). Loosen retaining screws (2 accessible from the top, 2 from the bottom) and remove the attenuator from below. For replacing, proceed in the reverse order. Check the mechanical functioning (pointer movement) and the electrical performance of the attenuator according to section 5.3.12 and that of the AGC amplifier according to 5.3.13.

4.19.5 Withdrawing the Overload Protector (Fig. 4-2)

Withdraw the signal generator from its cabinet as described in section 3.3.2. Pull the modulation unit out as described in section 4.19.2. Disconnect or unsolder the leads K9, K10 (in 41314 Bl.2), the +18-V and -18-V leads and the lead of the incandescent lamp (in 41314 S Bl.3) Loosen the retaining screws and remove the overload protector from above. For replacing, proceed in the reverse order.

4.19.6 Withdrawing the Power Supply

Withdrawing the Stabilizing Circuits (Fig. 4-6)

Withdraw the signal generator from its cabinet as described in section 3.3.2. Both plug-in stabilizing circuits can be pulled out of the multipoint connectors after loosening the respective screws on the frame. For the electrical check, see section 5.3.1.

Withdrawing the Power Supply Frame and the Cable Harness (Fig. 4-4): Unsolder five AC voltage leads, four DC voltage leads (Bu8, Bu9, Bu10, Bu11 battery operation) and three operating-voltage leads. Loosen four screws on the frame. Push the power supply frame and cable harness back and pull out from above (Fig. 4-4). For replacing, proceed in the reverse order. Electrical check according to section 5.3.1.

4.19.7 Withdrawing the Crystal Stage (Fig. 4-3, 4-4)

Withdraw the signal generator from its cabinet as described in section 3.3.2. Remove the cover of the oscillator (6 screws); then the rear side of the circuit board is accessible for measurements. Disconnect the coaxial cable (K3) from the crystal stage and unsolder the operating-voltage lead. The oscillator can be withdrawn after loosening the 3 screws on the frame. For replacing, proceed in the reverse order.

4.19.8 Withdrawing the FM Chokes (Fig. 4-1)

Withdraw the signal generator from its cabinet as described in section 3.3.2 and the amplifier according to section 4.19.10. Remove both covers. Find the location of the sub-assembly to be exchanged according to Fig. 4-1. Unsolder the connections of the subassembly concerned and remove the subassembly (in the case of 41311-2.95, remove the partition also). For replacing, proceed in the reverse order. Electrical check according to 5.3.3.

4.19.9 Withdrawing the Pushbutton Assembly and the Deviation Network (Fig. 4-5)

Withdraw the signal generator from its cabinet as described in section 3.3.2. Unsolder the leads of the cable harness. Loosen the three retaining screws. Swing the pushbutton assembly with the panel out of the frame and pull out.

4.19.10 Withdrawing the Amplifier (Fig. 4-1)

Withdraw the signal generator from its cabinet as described in section 3.3.2. Unsolder the cable harness at the 6-pole soldering lug strip, disconnect cables K1 to K10, unsolder the +18-V and -18-V operating-voltage leads of the overload protector and loosen the screws on the frame. Remove the chassis from above. For replacing, proceed in the reverse order. Electrical check according to sections 5.2 and 5.3.

All these subassemblies are located on the same chassis and are accessible from below.

4.19.11 Withdrawing the Buffer, AGC Circuit, Mixer, Modulator, Output Stage (Fig. 4-1)

Withdraw the signal generator from its cabinet as described in section 3.3.2 and put the set upside down. Remove the two covers (17 and 14 screws, respectively). The location of the subassemblies to be exchanged can be found by referring to Fig. 4-10. Unsolder the leads of the subassembly concerned. Loosen the screws and take the subassembly out. For replacing, proceed in the reverse order. Electrical check according to sections 5.2 and 5.3.

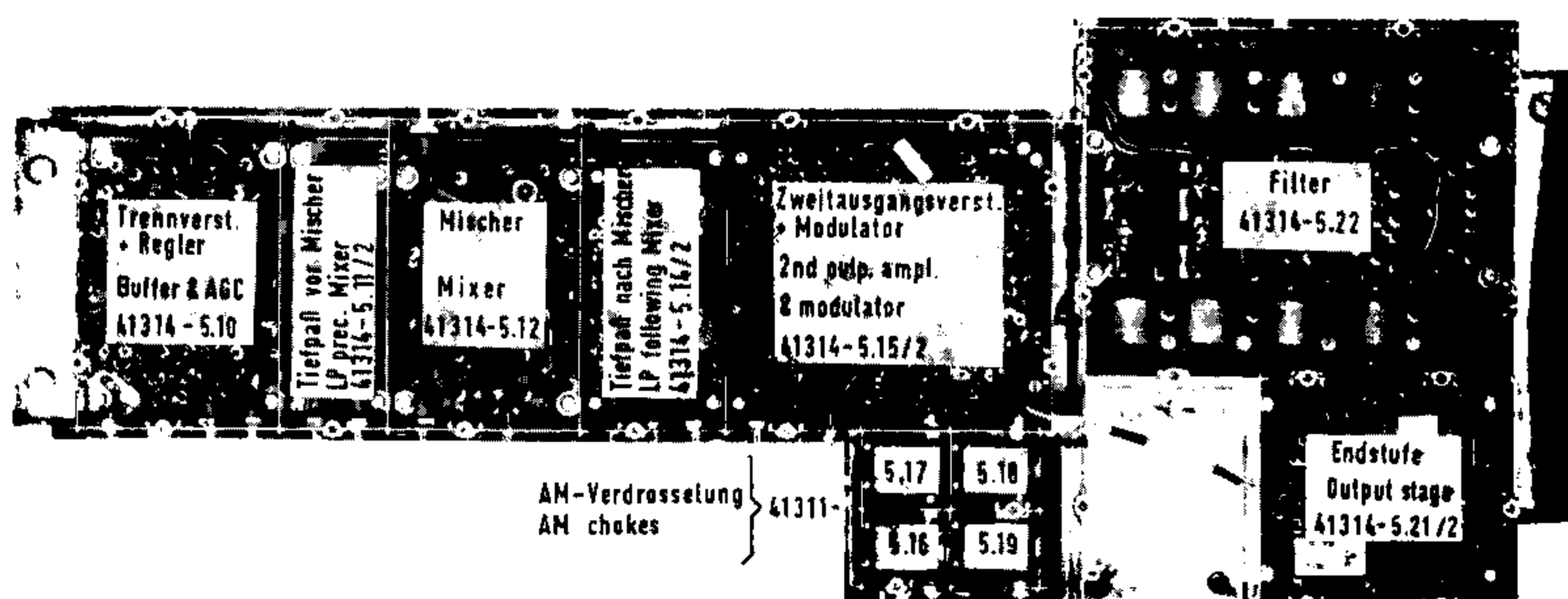

Fig. 4-10 Location of circuit boards on the chassis

5. Repair Instructions

5.1 Measuring Instruments and Auxiliary Equipment Required

The following table lists all measuring instruments and auxiliary equipment required for checking and calibration.

Designation and specifications	Type	BN	Uses section
UHF-DC Millivoltmeter AC voltage 2 mV to 300 V Frequency range 1 kHz to 1.6 GHz Error of voltage indication $\pm 8\%$ of f.s.d. DC voltage 1 mV to 1000 V Error of voltage indication $\pm 8\%$ of f.s.d. with Insert Unit 100.0147 and probe (above 300 MHz to be used as indicator only - appreciable error)	URV	100.0130.02	5.3.11 5.3.12 5.3.13 5.4.6
Millivoltmeter Frequency range 10 Hz to 1 MHz Voltage range 0.1 mV to 300 V, -80 to +52 dB Error of voltage indication $\pm 2\%$ of f.s.d. Input resistance 1 M Ω , shunted by 30 pF.	UVN	100.0160.02	5.4.8
Digital Multimeter AC voltage 100 μ V to 700 V _{rms} Frequency range 20 Hz to 20 kHz DC voltage 100 μ V to 1000 V Resistance range 1 to 15 M Ω	UGWD	100.0218.02	5.4.9
RC Oscillator Frequency range 10 Hz to 1 MHz Output voltage 0 to 30 V continuously adjustable at $Z_{out} \approx 20$ to 60 Ω	SRB	100.4094	5.3.15
Power and Standard Signal Generator Frequency range 30 kHz to 31 MHz Output voltage EMF 0 to 10 V into 60 Ω	SMAR	100.4513.02	5.4.9
Power Signal Generator Frequency range 30 to 300 MHz Output voltage EMF 0 to 3 V into 60 Ω	SMLM	100.4413.02	5.3.11
Power Signal Generator Frequency range 0.1 to 30 MHz Output voltage EMF 0 to 10 V into 60 Ω	SMLR	100.4171.02	5.3.11
VHF Signal Generator Frequency range 22.5 to 480 MHz Output voltage EMF 0 to 3.5 V into 60 Ω	SLSV	100.4188.02	5.4.3 5.4.9
UHF Power Signal Generator Frequency range 0.275 to 2.75 GHz Output voltage EMF -50 to +45 dBm ($P_{max} = 35$ W)	SLRD	100.4194.02	5.3.13

Designation and specifications	Type	DN	Uses section
Field-Strength Meter Frequency range 0.1 to 30 MHz Voltage range 0 to 120 dB above 0.1 μ V (0.1 μ V to 0.1 V)	HFH	100.1014.02	5.3.11
VHF-UHF Monitoring Receiver with the 4 RF Plug-in Units 100.1189.02 at 25 to 230 MHz 100.1195.02 at 160 to 470 MHz 100.1208.02 at 460 to 900 MHz 100.1214.02 at 850 to 1300 MHz Input voltage for all RF Plug-in Units 0 to 120 dB above 1 μ V (1 μ V to 1 V)	ESU	100.1143.02	5.3.11 5.4.11
Limit Bridge Parameter R, L, C Measurement range: ± 0.1 to 25 % Error of measurement range ± 5 % of f.s.d.	KZS	100.1950.02	5.5.2
YT Recorder	ZSG 2	110.2007.92	5.5.2
Oscilloscope Tektronix Type 545 with Type L and Type Z plug-in units Bandwidth 20 MHz			5.4.9
Microwave Power Meter Frequency range 0 to 4.8 GHz (0 to 13 GHz with Dezifix A connector) Power range 0.1 to 330 mW	NRS	100.2433.92	5.3.11 5.4.4
800-MHz-Counter with 800-MHz Plug-in 100.6080.02 Frequency range 10 to 800 MHz Error limits $\pm 10^{-10}$	FET 2	100.6039.02	5.4.6 5.4.8
UHF Attenuator Set Frequency range 0 to 2000 MHz Attenuation 0 to 140 dB Accuracy ± 0.05 to 1 dB	DPU	100.8960.50	5.3.11 5.3.12
Power Supply Voltage range 0 to 32 V Current range 0 to 30 A Resolution 1 mA	NGR	100.5084 . .	5.3.13
SHF Termination	RMC	100.2940.50	5.3.11 5.3.13
Battery (2 ea) 24 V, $I_{max} = 0.5$ A Adapter ($Z = 50 \Omega$) N connector system \longleftrightarrow Dezifix B ¹⁾ Dezifix B ¹⁾ \longleftrightarrow Subminax socket Dezifix B ¹⁾ \longleftrightarrow Subminax plug Cable ($Z = 50 \Omega$) Dezifix B ¹⁾ \longleftrightarrow Subminax plug Dezifix B ¹⁾ \longleftrightarrow Subminax socket N connector system \longleftrightarrow Dezifix B ¹⁾ Dezifix B ¹⁾ \longleftrightarrow Dezifix B ¹⁾ BNC \longleftrightarrow 4/13 ¹⁾			

¹⁾ These connectors apply to R&S instruments only

5.2 Trouble-shooting (see level plan Fig. 5-16)

5.2.1 Power Supply

Prior to trouble-shooting in the SMDA check that the rated power supply values are maintained, e. g. AC supply voltage $220 V_{rms} \pm 10\%$. Press the POWER button: The pilot lamp must light. If it does not light, the power cable, power switch, fuse or the lamp itself may be defective. Measure the voltage at socket Bu70 (in circuit diagram 41314 S Bl.3).

Checking the operating voltage: Withdraw the set from its cabinet (see section 3.3.2) and measure the operating voltages $\pm 18 V \pm 0.1 V$ at the outputs "+", "-" and "±" of the printed cable harness (Fig. 4-4).

NOTE: Adjust only if the frequency or deviation accuracy and the output power do not correspond to the specifications of section 1.3. If an adjustment is necessary, the +18-V voltage can be corrected with R662 and the -18-V voltage with R682 to within $\pm 0.1 V$. If no adjustment is possible or if no voltage is measurable, check the power supply according to section 5.3.1. After adjustment of the operating voltage, check frequency, deviation, output voltage and the overload protection.

5.2.2 RF Voltage

Trouble: RF voltage failure in one or all ranges.

Preliminary check: If the modulation unit functions properly, part of the RF generation can be checked by means of the AM indication. Set the INDICATION switch to AM, the range selector to 100, the AM switch to INT. and the AM control to mid-position. The positions of the other switches are of no importance.

Then press the frequency range buttons one after the other and adjust for a medium frequency in each range. The meter of the modulation unit should show mid-scale deflection in each case. If no deflection is obtained, check according to the following table:

No output voltage in range	Possible trouble source	Check according to section
All ranges	RF OUTPUT II	5.2.2
I	Oscillator IV	5.3.2
I	Crystal-stage + relay in the mixer	5.3.2 and 5.3.5
I+II+III	Output filter III	5.3.10
IV	Output filter IV and oscillator IV	5.3.2 and 5.3.10
VI	Output filter VI and oscillator VI	5.3.2 and 5.3.10
VII	Output filter VII and oscillator VII	5.3.2 and 5.3.10
II to VII	Relays in the mixer	5.3.5
indication in all ranges	RF attenuator and overload protector	5.3.11 and 5.3.13

Table 5 Fault location in case of RF voltage failure

RF OUTPUT II: After prechecking (no deflection with the AM indication) measure the second output voltage according to section 5.3.7.

- a) No voltage present: Check the oscillator (see below), buffer, control circuit, mixer and second output amplifier. See sections 5.3.2, 5.3.4., 5.3.5, 5.3.7 and Fig. 5-16.

Output voltages (operating voltages) at the outputs "+", "-" and "±" of the printed cable harness 41311-4.5 $\pm 18\text{ V} \pm 0.1\text{ V}$

NOTE: Prior to the adjustment, follow the instructions given in sections 5.2.1 and 5.4.1.

Check to operating voltages of $\pm 18\text{ V} \pm 0.1\text{ V}$ of the subassemblies at the respective connections according to the circuit diagram.

Measure the hum and noise voltages at the operating-voltage leads with an oscilloscope at AC supply voltages of 198, 220 and 242 V_{rms} . Hum and noise must be $< 0.1\text{ mV}_{\text{pp}}$.

The offset, i. e. the variation of the operating voltages, must be $< 0.1\text{ mV}$ at AC supply voltage variations from 198 to 242 V_{rms} .

The power consumption of the subassemblies from the power supply must be $< 450\text{ mA}$ for the +18-V lead and $< 120\text{ mA}$ for the -18-V lead.

Battery operation: If two separate DC voltages ($24\text{ V} \pm \frac{5}{2}\text{ V}$ each) are fed to the battery sockets at the rear of the signal generator, the same values must be obtained as in the measurement of the output voltages.

NOTE: The power supply does not withstand permanent short circuit. Short circuits of 1 to 2 minutes do not cause damage unless they occur at very short intervals.

5.3.2 Oscillator

For the mechanical procedure to be followed for opening the oscillator, see section 4.19.3. The correlation of the frequency ranges and the oscillator segments is also shown in this section.

Checking the operating voltage of the oscillator (-18 V): The operating voltage is fed to the oscillator segments from below via lead-through chokes (deviation network); see Fig. 5-1. Press the button of the frequency range concerned. Turn the tuning knob until the dial drum has made a full revolution. The operating voltage must be present with the pointer (coloured arrow) up to 1 cm beyond the scale ends. Further off, no operating voltage must be present.

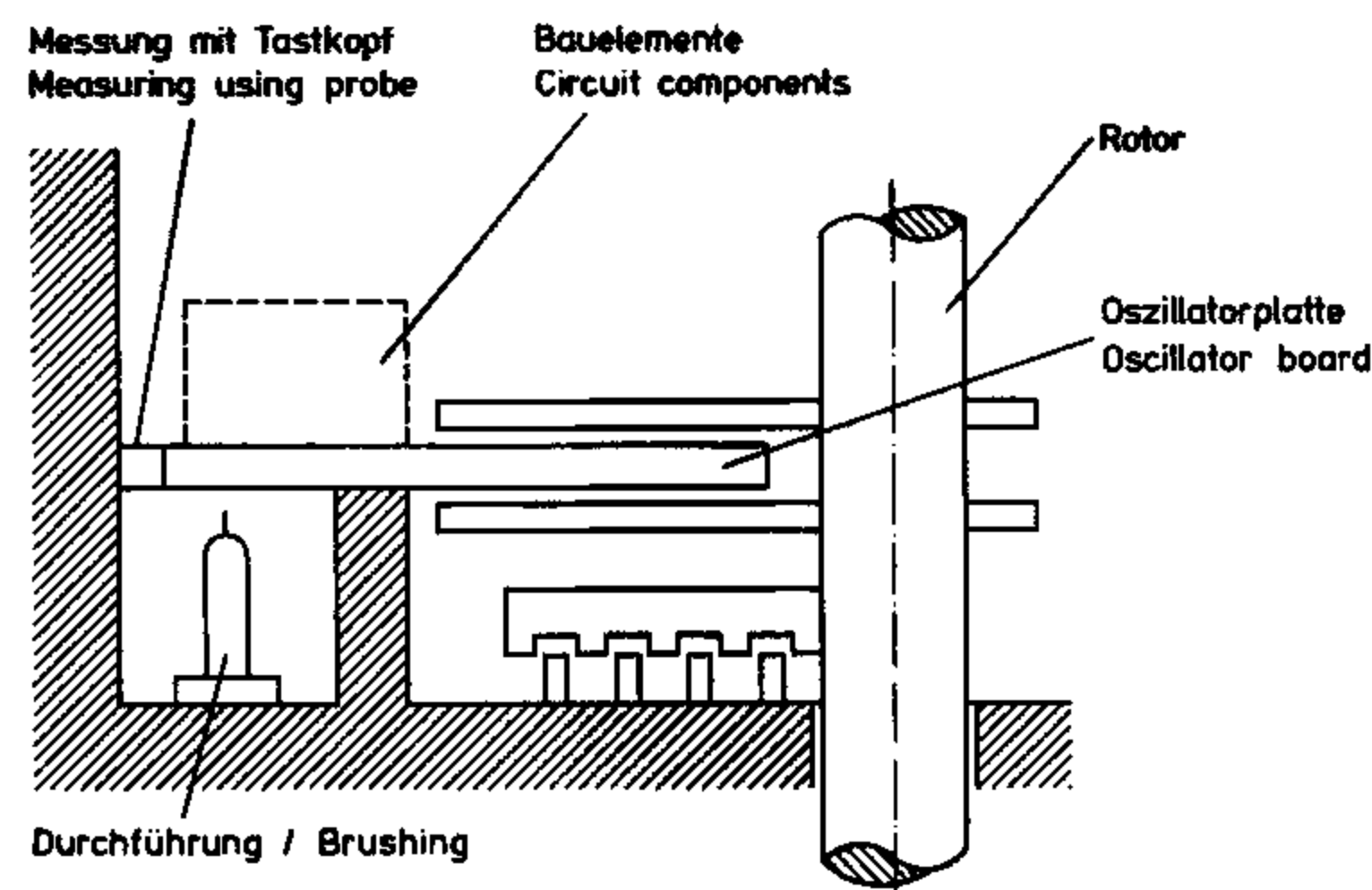

Fig. 5-1 Construction of oscillator

Checking the current consumption: No button must be pressed. Measure at the pushbutton assembly according to Fig. 5-2 using a milliammeter 0 to 10 mA, $Z_{in} < 10 \Omega$. The current consumption should be 2 to 7 mA.

Checking the RF voltage: Measure the RF voltage at the star point of the isolating resistors R801 to R806 (output) with a UHF-DC Millivoltmeter Type URV ($Z_{in} > 20 k\Omega$). Press the button of the frequency range being checked. Tune through the whole range. The RF voltage must be 30 to 70 mV.

At oscillator temperatures up to 60 °C (heat with a hot-air blower), the output voltage must not drop below 30 mV. The waveform of the oscillator output voltages should be sinusoidal in the whole frequency range. A rough check can be made with a sampling oscilloscope (at K1). For precision measurements, use a test receiver and tune to any harmonic present.

Harmonic suppression

Ranges II, III, IV and V > 30 dB
 Ranges VI and VII > 26 dB

Performance check of ranges II, III and VI being cut off by range VII: The diodes G1411, G1401 and G1371 short-circuit certain of the sections oscillator circuits and deviation networks of ranges II, III and VI when range VII is cut in. A voltage between +16 V and +18 V must be present at the cathodes of the diodes G1411, G1401 and G1371 if the ranges II to VI are selected. If range VII is selected, a voltage between -1.0 V and -1.6 V must be present at the cathodes of the diodes G1411, G1401 and G1371.

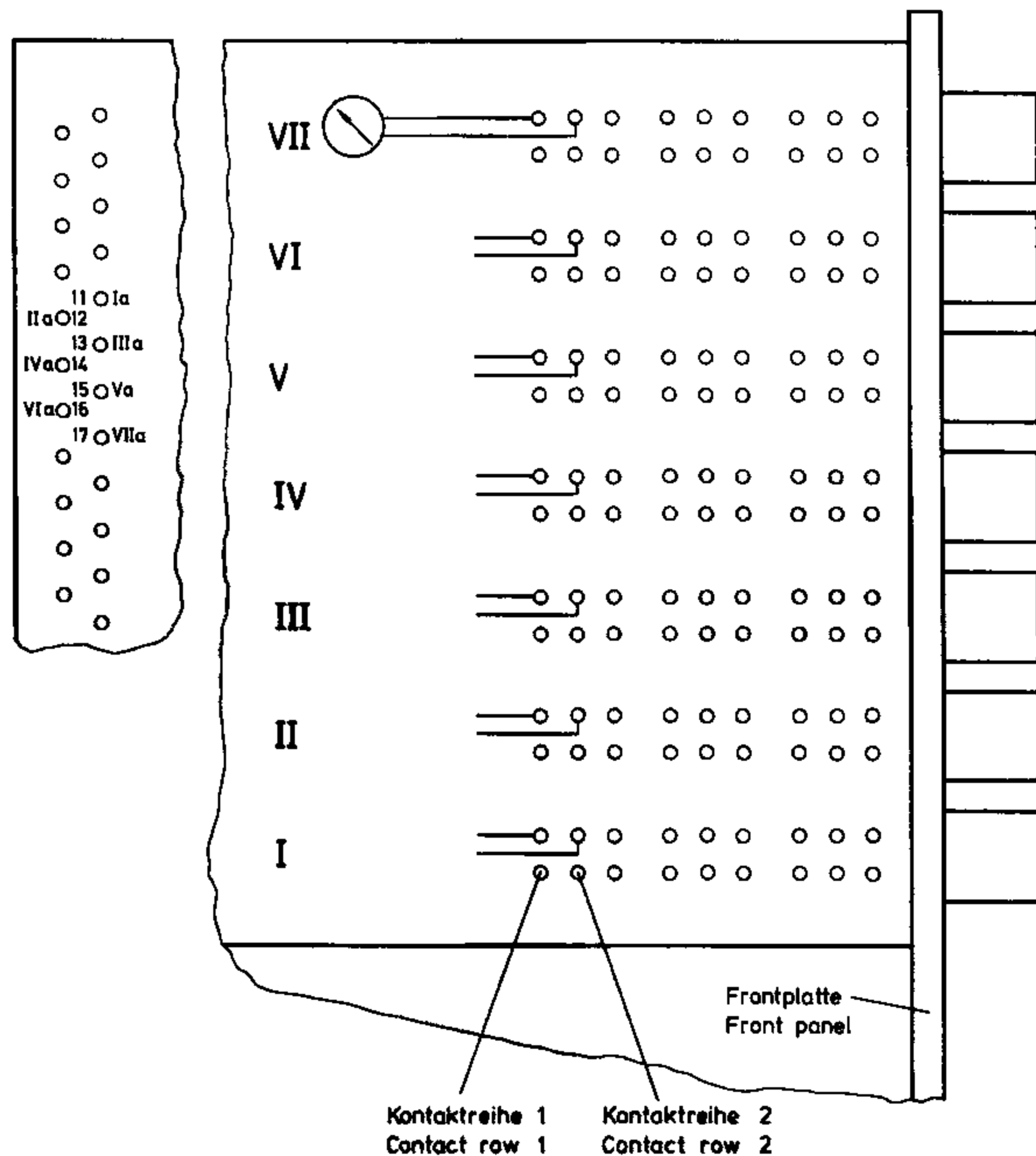

Fig. 5-2 Key set with test points

Checking the frequency deviation

Frequency deviation with DC: Unsolder link 1-2 in the deviation network 41314-2.100.25 and replace by a switch. Connect a frequency counter (FET 2 with 800-MHz plug-in) to the SMDA. Press the button of the frequency range being checked; no modulation must be present. A frequency deviation is produced by turning the switch replacing the soldered link 1-2 on and off. Measure the frequency deviation at the upper limit, at the centre and at the lower limit of the frequency range. The frequency deviation should be roughly equal at the three frequencies. The permissible departure of the value at the range ends from that measured at the centre is $< 4\%$. Remove the switch and resolder link 1-2.

Frequency modulation: Check according to section 3.2.3.5.

Checking the oscillator frequency: Proceed according to section 3.2.1.2.

5.3.3 FM Chokes and Operating-voltage Leads (see circuit diagram 41314 S Bl.1)

Since the FM chokes and the operating-voltage leads are not immediately accessible, it is recommended that the deviation network (section 5.3.16) and the operating voltages at the pushbutton contact rows 1 and 2 (Fig. 5-2) and soldering lugs 1a to VIIa (Fig. 4-7) be always checked first. For the mechanical procedure to be followed for withdrawing the FM chokes, see section 4.19.8.

DC voltage check: Unsolder cable K11 and transistor T42. Check the connection from C423 to C425 (resistance $< 1\ \Omega$). Measure the isolation of the line to chassis (resistance $> 1\ M\Omega$). Check cable K11: A DC voltage of about $+7.8\ V$ (without modulation) must be present at the inner conductor.

5.3.4 Buffer and AGC

For the mechanical procedure to be followed for withdrawing the subassembly, see section 4.19.11. Check the DC voltages according to the circuit diagram 41314 S Bl.2. Tolerances of $\pm 10\%$ are permissible. Separate the control circuit (unsolder the inner conductor K2 from lead-through choke D3). Feed in a DC voltage continuously adjustable from approx. $-9\ V$ to $-10\ V$.

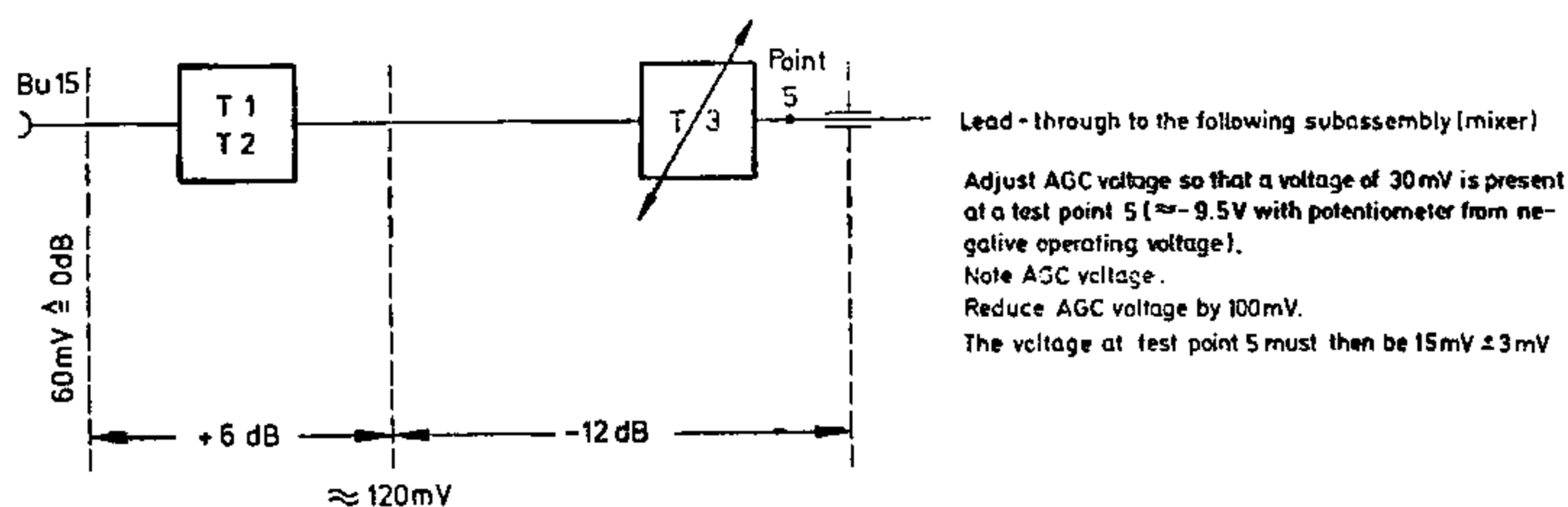

Fig. 5-3 Level schedule for the measurement of the RF levels at the buffer and AGC amplifier

RF level check: Test frequencies: 48 MHz (range II), 400 MHz (range VII). Measure with UHF-DC Millivoltmeter Type URV ($Z_{in} \geq 50\ k\Omega$; $C_{in} \leq 1\ pF$). See level diagram Fig. 5-3.

Checking the frequency response: The measurements are carried out with Polyskop SWOB II or SWOB III. Adjust the Polyskop as follows:

- a) Put the EMF line in the upper third of the screen.
- b) Set the output attenuator to -20 dB and connect the RF output (A) with the RF input (B) via a $50\text{-}\Omega$ cable.
- c) Bring the cable line to coincidence with the EMF line by means of button "Vertical gain Y1". This line serves as reference line for the 0-dB amplification between (A) and (B).

Connect the RF output of the Polyskop with socket Bu15 and the RF input with soldering terminal 5. First apply a DC voltage of -10 V to soldering terminal 3 so that the AGC circuit opens; then apply a DC voltage of -9 V so that the AGC circuit closes and carry out the following measurements:

Frequency/MHz	50	100	200	300	400	500
Gain/dB with -10 V at terminal 3	14 ± 1	13 ± 1	12 ± 1	11.5 ± 1	11 ± 1	9 ± 1
Gain/dB with -9 V terminal 3	≥ 14	≥ 14	≥ 14	≥ 14	≥ 14	± 10

Table 6 Checking the frequency response of AGC

5.3.5 Mixer

The mixer consists of three printed circuit boards. Board 1: Low-pass filter preceding mixer 41314-5.11/2. Board 2: Mixer and null detector amplifier (calibration) 41314-5.12. Board 3: Low-pass filter following mixer 41314-5.14/2. For the mechanical procedure to be followed for withdrawing the subassembly, see section 4.9.11.

Checking the relays: Measure with a continuity tester at points a-(a), b-(b) and c-(c), d-(d) = no button pressed; a-c and e-b = range I button depressed; a-b = range II to VII buttons depressed. See Fig. 5-4. Press the frequency-range buttons one after the other.

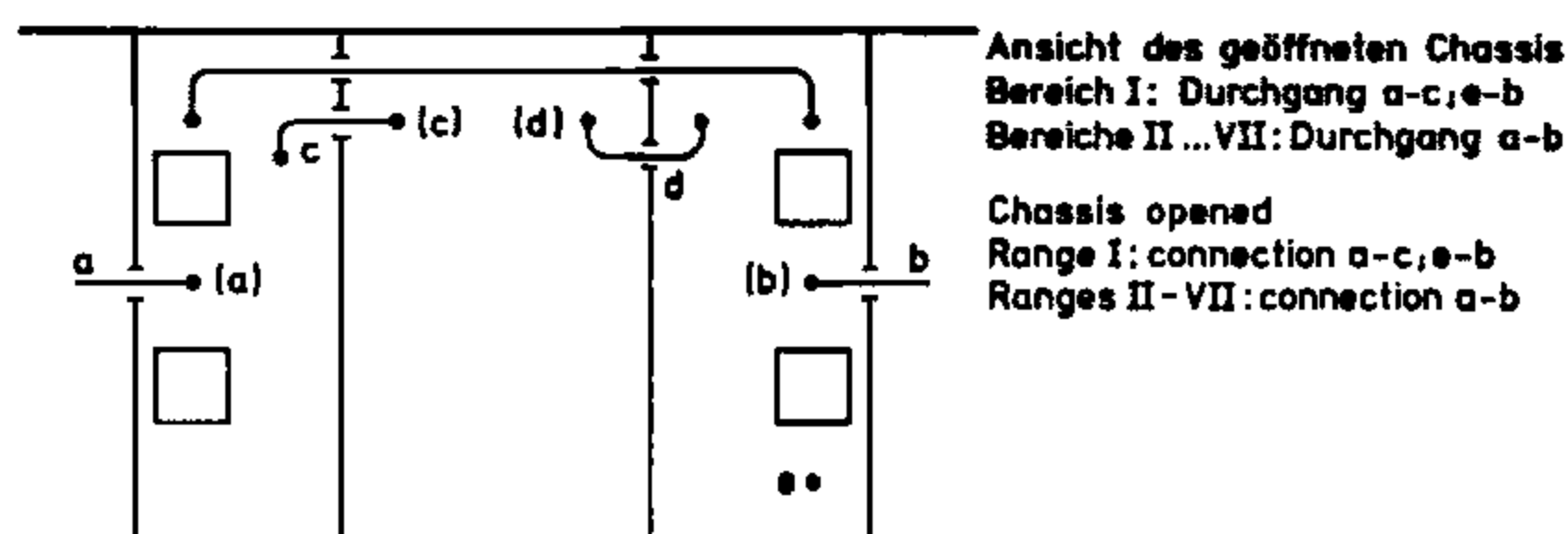

Fig. 5-4 Checking the relay of the mixer

Checking the mixer: Measure the signal voltage (≥ 1 V_{rms}) at C83 selectively (129 MHz) with the VHF-UHF Test Receiver Type ESU. Measure the oscillator voltage at C74 selectively with the Test Receiver Type ESU. Measure the diode current at R84 with the DC-UHF Electronic Multimeter Type URV (DC input 1 : 1; $Z_{in} = 1$ M Ω) or with Type UGWD. The voltage drop resulting from the diode current must be approx. 600 mV.

Checking the null detector amplifier: Check the DC levels according to the circuit diagram 41314 S Bl.2. Observe the reading of meter J1 (zero beat indicator). Select range I and change the frequency tuning from the calibration mark to the left or right. For meter reading, see Fig. 5-5.

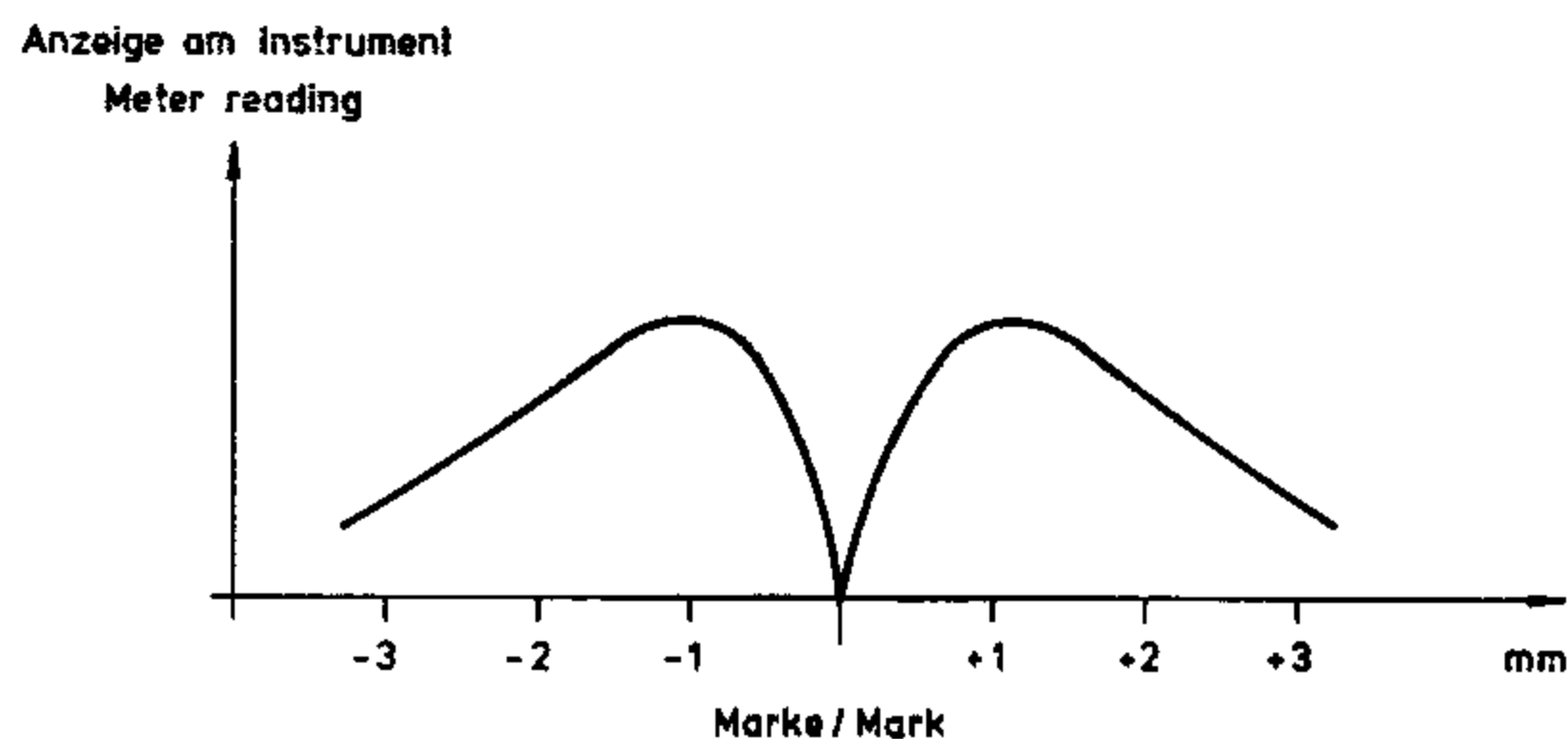

Fig. 5-5 Rated meter reading for checking of meter amplifier

Checking the frequency response: Measure as described in section 5.3.4.

- a) Low-pass filter ahead of the mixer 41314-5.11/2: Connect the RF output of the Polyskop with soldering terminal 47 and the RF input with soldering terminal 8. At a frequency ≤ 180 MHz (129 to 179 MHz) the attenuation must then be 15 ± 1 dB. At 220 MHz the attenuation must be greater than 25 dB.
- b) Low-pass filter after the mixer 41314-5.14/2: Connect the RF output of the Polyskop with soldering terminal 10 and the RF input with terminal 22. In the frequency range 0.4 to 50 MHz the gain must be 24 ± 1 dB.
- c) Mixer 41314-5.12 and low-pass filter after the mixer 41314-5.14/2: Connect the RF output of the Polyskop with soldering terminal 10 and the RF input with terminal 22. Apply an RF voltage of 20 mV to soldering terminal 10, which corresponds to an attenuator position of -30 dB on the Polyskop. In the range 130 to 180 MHz the gain must then be 14 ± 2 dB.

5.3.6 Crystal Stage

For the mechanical procedure to be followed for removing the crystal stage, see section 4.19.7. Measure the operating voltage (+18 V) at the lead-through choke (D33) of the crystal stage. The operating voltage must be present in frequency range I; in the other ranges, no operating voltage must be present. Check the DC voltages according to the circuit diagram 41314 S Bl.2 in the frequency range I. Measure the output voltage at socket Bu27 of the crystal stage, using the UHF-DC Millivoltmeter Type URV plus Insertion Unit terminated with 50Ω . It must be $> 1.0 V_{rms}$. Measure the output frequency at Bu27 with the Electronic Counter Type FET 2 ($Z_{in} = 50 \Omega$) or Frequenzkontroller. It must be $129 \text{ MHz} \pm 10 \text{ kHz}$.

For **adjustment**, see section 5.4.5.

5.3.7 Second-output Amplifier

For the mechanical procedure to be followed for removing the subassembly, see section 4.19.10. Check the DC voltages according to circuit diagram 41314 S Bl.2. Tolerances

of $\pm 10\%$ are permissible. No modulation should be cut in. Measure the RF levels at 0.4 MHz (range I) and 400 MHz (range VII) with the UHF-DC Millivoltmeter Type URV ($Z_{in} \geq 50 \text{ k}\Omega$, $C_{in} \leq 1 \text{ pF}$). The attenuation between points 27 and 24 should be approximately 10 dB. The output voltage into 50Ω must be between > 15 and $< 45 \text{ mV}_{rms}$ at attenuator settings $< 0.5 V_{EMF}$ and $< 75 \text{ mV}_{rms}$ at attenuator settings $> 0.5 V_{EMF}$.

Adjustment: Adjust the attenuator pad R210 (in the output stage 41314-5.21/2) such that at an attenuator position of -20 dBV the voltage at the RF OUTPUT II is 20 mV at 115 MHz (see Fig. 5-16).

Checking the frequency response: Measure as described in section 5.3.4. Connect the RF output of the Polyskop with soldering terminal 27 and the RF input with socket Bu5 RF OUTPUT II. In the range 0.4 to 480 MHz the attenuation must be $10 \pm 1 \text{ dB}$.

5.3.8 Buffer and Modulator

For the mechanical procedure to be followed for removing the subassembly, see section 4.19.10. Check the DC voltages according to the circuit diagram 41314 S Bl.2. Tolerances of $\pm 10\%$ are permissible. No modulation should be cut in. Measure the RF levels as described in section 5.3.7 (level diagram, Fig. 5-16). The input voltage at Bu15 should be about 50 mV and the output voltage at C161 (point 23 on 41314-5.15/2) 130 mV , min. Level variations of $\pm 2 \text{ dB}$ are permissible.

Checking the modulator: Select range I and adjust for a frequency of 1 MHz. Measure the levels according to the circuit diagram 41314 S Bl.2, using the UHF-DC Millivoltmeter Type URV ($Z_{in} = 50 \text{ k}\Omega$, $C_{in} \leq 1 \text{ pF}$). Then cut in modulation. Set the switch 8 for $f_{mod} = 1 \text{ kHz}$, AM switch to INT. and adjust knob 11 for 85% amplitude modulation. Measure the AF distortion at the output Bu14 for connection of the VOR-ILS Unit, using a distortion meter, such as Type FTZ. To do so, adjust potentiometer R130 (in the modulator 41314-5.15/2) starting from its midway position so that the AF distortion is at a minimum at 115 MHz and 335 MHz. At the attenuator setting 0 dBV the AF distortion must be less than 2.5% in all frequency ranges. The gain between the points 27 and 23 should be $9 \text{ dB} \pm 1.5 \text{ dB}$.

Checking the modulation feedback: Check the modulator and adjust for $f_{mod} = 1 \text{ kHz}$ and $m = 50\%$. Measure the AF level at the collector of T9. It should be about $0.3 V_{pp}$. Disconnect cable K5 from socket Bu18. The AF level at the collector of T9 should then rise to about $2.4 V_{pp}$. If no AF voltage is present, check the AGC amplifier according to section 5.3.12. If no meter reading is obtained, check the continuity from R148 to cable K7.

Modulation frequency response: Set the AM selector to EXT. and adjust the rotary knob "AM" for a modulation depth of 80%. Modulation frequency $f_{mod} = 90 \text{ Hz}$ and 150 Hz and the carrier frequency = 115 MHz and 335 MHz. At a constant level at input AM-EXT., the fluctuations of the voltage at the output for connection of the VOR-ILS Unit, Bu14.1, Bu14.2, Bu14.3, to chassis must not be greater than 2×10^{-4} . At excessive fluctuations, the correcting network R165, C165 at the emitter of T9 must be adjusted by slightly changing R165.

Checking the frequency response: Measure as described in section 5.3.4. Connect the RF output of the Polyskop with soldering terminal 27 and the RF input with terminal 23. In the range 0.4 to 480 MHz the gain must be $7 \pm 1.5 \text{ dB}$. The balancing potentiometer R130 affects the gain independent of the frequency.

5.3.9 Output stage

For the mechanical procedure to be followed for removing the subassembly, see section 4.19.10. Check the DC voltages according to the circuit diagram 41314 S Bl.2. The

emitter voltage of T25 is adjusted with R222, so that output voltage 500 mV and modulation depth 95 % also for frequencies > 400 MHz. Measure the RF levels at 0.4 MHz (range I) and 400 MHz (range VII) with the UHF-DC Millivoltmeter Type URV ($Z_{in} \geq 50 \text{ k}\Omega$; $C_{in} \leq 1 \text{ pF}$). The input voltage must be between 120 and 200 mV and the output voltage about 700 mV. The RF level is adjusted with R210 (see section 5.3.7).

Checking the frequency response: Measure described in section 5.3.4. Connect the RF output of the Polyskop with the soldering terminal 44 and the RF input with terminal 46. In the range 0.4 to 480 MHz the gain must be $16 \pm 1.5 \text{ dB}$, if minimum attenuation is adjusted with R210.

5.3.10 Filter

For the mechanical procedure to be followed for removing the subassembly, see section 4.19.10.

Checking the relays: Check the connection between the lead-through to the output stage, check point 46 and the inner conductor Bu19 with a continuity tester. If none of the frequency-range buttons I to VII is depressed, there must be no through-connection. Press the buttons I to VII one after the other; a through-connection should exist in each case.

Attenuation characteristic: Unsolder link 46 \longleftrightarrow 6 (41314 S Bl.2) at capacitor C252 and apply a voltage of about $0.5 V_{rms}$ (20 MHz to 600 MHz) from a signal generator ($Z_{out} = 50 \Omega$). Measure the voltage at the filter output (inner conductor Bu19) terminated with 50Ω . The output voltage should comply with the following curve if buttons III to VII are depressed one after the other:

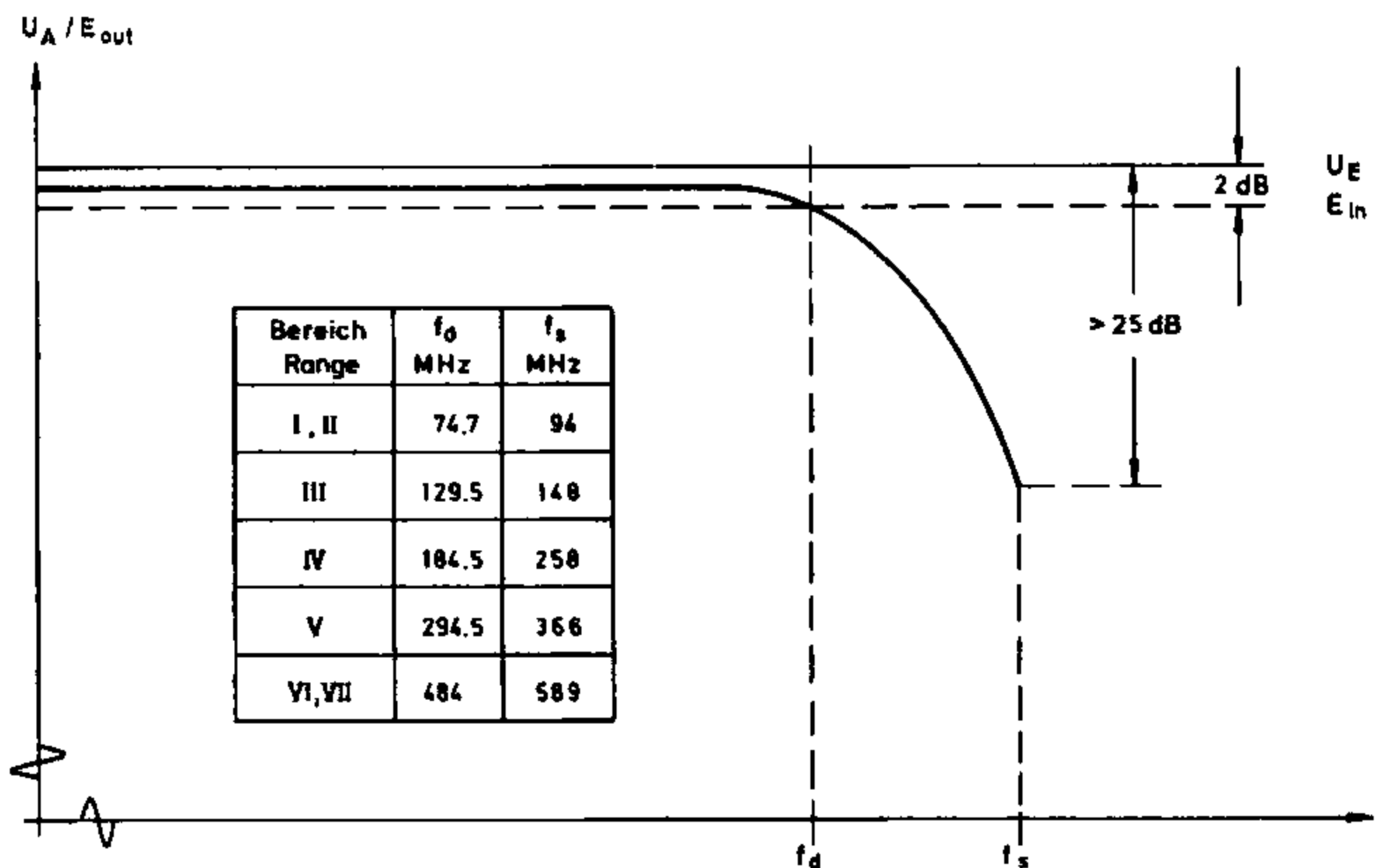

Fig. 5-6 Voltage at the filter output

5.3.11 Attenuator

For the mechanical procedure to be followed for removing the attenuator, see section 4.19.4. The attenuator can be checked within the set. Feed a test voltage to Bu22 and measure it at the signal-generator output. The SM DA must be switched on (overload protector).

Test setup

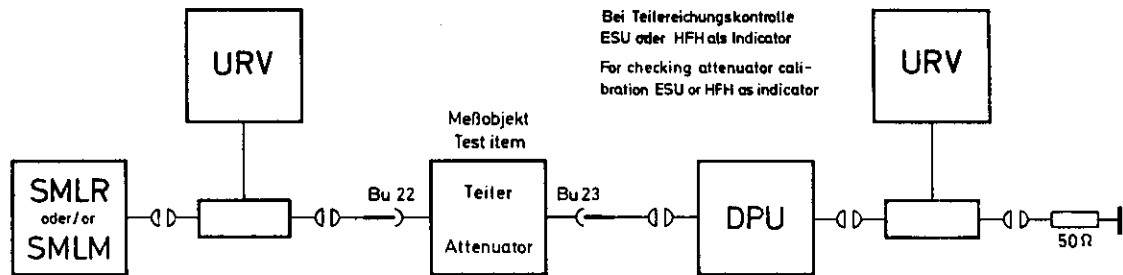

Fig. 5-7 Test setup for checking the attenuator function

Attenuator function: When the attenuator is turned through its range, the voltage at the voltmeter must decrease or increase uniformly (no jumps).

Scale calibration: Adjustments: Set the attenuator to 0 dBV using the cranc-type knob and adjust the attenuator set to 120 dB. Increase the voltage of the SMDA (max. 1 V_{rms}) until the indication of the receiver voltmeter is about $\frac{3}{4}$ of full-scale value. Note this value. Set the SMDA to 0.4 MHz, 50 MHz and 400 MHz. Vary the attenuations of the attenuator set and of the SMDA attenuator inversely by equal amounts (e. g. 10 dB) and read the voltmeter indication. The input voltage of the attenuator must be kept constant. For this purpose, check the input voltage with the URV insertion head (rough check), or, still better, the rectified voltage (approx. 0.7 V DC voltage) at the output of the meter diode G1260 (C260) according to Fig. 27 and stabilize with the signal-generator voltage.

The voltmeter reading (test-receiver reading) may vary by < 1 dB.

Meter diode

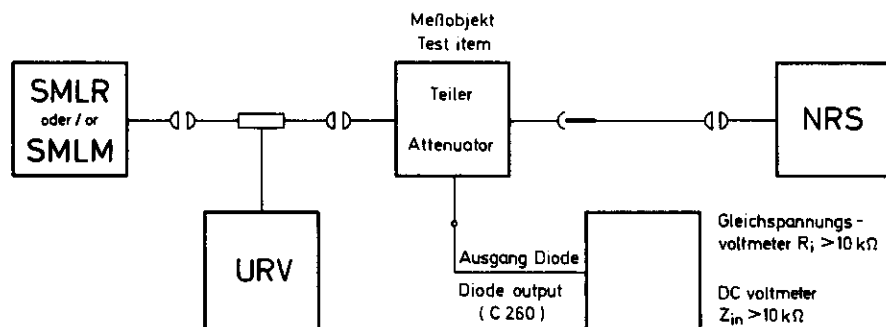

Fig. 5-8 Test setup for checking the diode of the attenuator

Vary the frequency in the range 0.4 to 480 MHz at a constant RF voltage across the test item (SMDA attenuator). The DC voltage at the output (C260) of the diode G1260 must be $0.7 \text{ V} \pm 5\%$ if the supply voltage = 0.7 V (corresponding to 1.4 V EMF). The (rectified) DC voltage must not vary more than 1 % in the whole frequency range.

5.3.12 AGC Amplifier

For the mechanical procedure to be followed for removing the attenuator with AGC amplifier, see section 4.19.4. The performance check can usually be made if the cover of the AGC amplifier is unscrewed (accessible from the bottom of the signal generator). Check the DC voltages according to circuit diagram 41314 S Bl.2. Tolerances of $\pm 10\%$ are per-

missible. These values hold for an RF voltage of $0.7\text{ V} \pm 10\%$ at Bu22 (attenuator input) if the AGC amplifier is in full operation.

AGC voltage

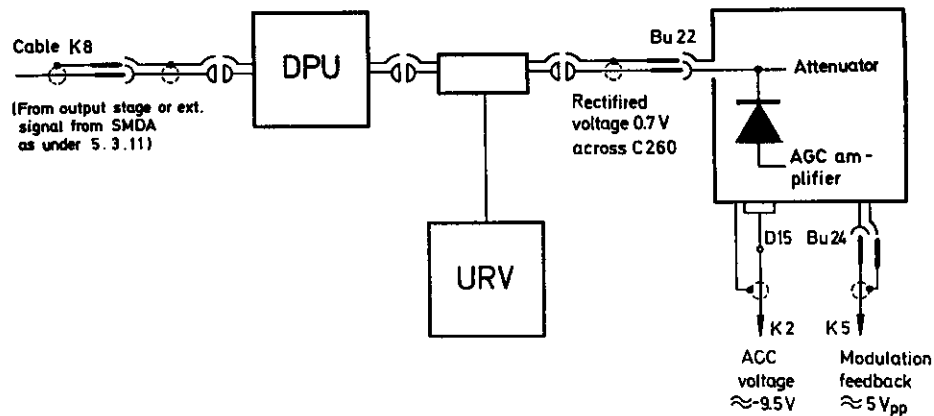

Fig. 5-9 Test setup for checking AGC voltage

Test frequencies are 0.4 and 480 MHz; no modulation is cut in. If the input voltage at Bu22 is decreased, the AGC voltage at D15 (K2 disconnected) must change by ΔE . Adjust the attenuator set to 0 dB corresponding to about 0.7 V at Bu22 and measure the AGC voltage. The rating is $-9.5\text{ V} \pm 5\%$. Note the accurate value measured for reference. Adjust the attenuator set to 6 dB; the AGC voltage must then rise by about 1.75 V.

Measuring the modulation feedback: Apply a modulated signal (50% modulation; $f_{\text{mod}} = 1\text{ kHz}$). Connect cable K8 to Bu22 if the voltage is taken from the SMDA itself. Measure at Bu24 (inner conductor) with the Millivoltmeter Type UVN ($Z_{\text{in}} \geq 100\text{ k}\Omega$; $C_{\text{in}} < 50\text{ pF}$). The voltage level should be $3.75\text{ V}_{\text{pp}} \pm 10\%$.

Deviation measurement socket: Feed a test signal at a frequency the same as that of the SMDA to output 16. Set the output attenuator to the points marked green ($> 1\text{ W}$, $< 1\text{ W}$) and feed the following voltages to output 16:

Attenuator setting	Test voltage at 16
$> 1\text{ W} = 0.2\text{ V}_{\text{EMF}}$	0.7 V 3.2 V
$< 1\text{ W} = 1\text{ V}_{\text{EMF}}$	0.1 V 0.7 V

Table 7 Checking of the deviation measurement socket

With an IF of 111 kHz, a voltage of $\geq 20\text{ mV}$ to chassis must be present at Bu7R.

Checking the test output Bu14 for the VOR-ILS unit:

Select a modulated signal of 40% modulation depth at 115 MHz. At the socket Bu14.1, the following voltages must be measured to chassis (Bu14.2, 3): an AF voltage of $990\text{ mV} \pm 1\text{ mV}$, a rectified voltage of $-3.5\text{ V} \pm 5\text{ mV}$, a maximum offset voltage of +30 mV. When the contacts .4 and .5 of the socket Bu14 are short-circuited, the carrier at the output Bu14.1 must be attenuated by at least 40 dB.

Adjustment of AGC amplifier and Rectified-voltage compensator see section 5.4.4.

5.3.13 Overload Protector

For the mechanical procedure to be followed for removing and checking the overload protector, see section 4.19.5.

Checking the relay function: Check connection (test voltage $< 1\text{ V}$) between the inner conductors of Bu25 and of Bu26 with a continuity tester. If no operating voltage is present, there must be no through-connection. If the operating voltage of $+18\text{ V}$ or -18 V is present, a through-connection should exist.

Response threshold with DC voltage

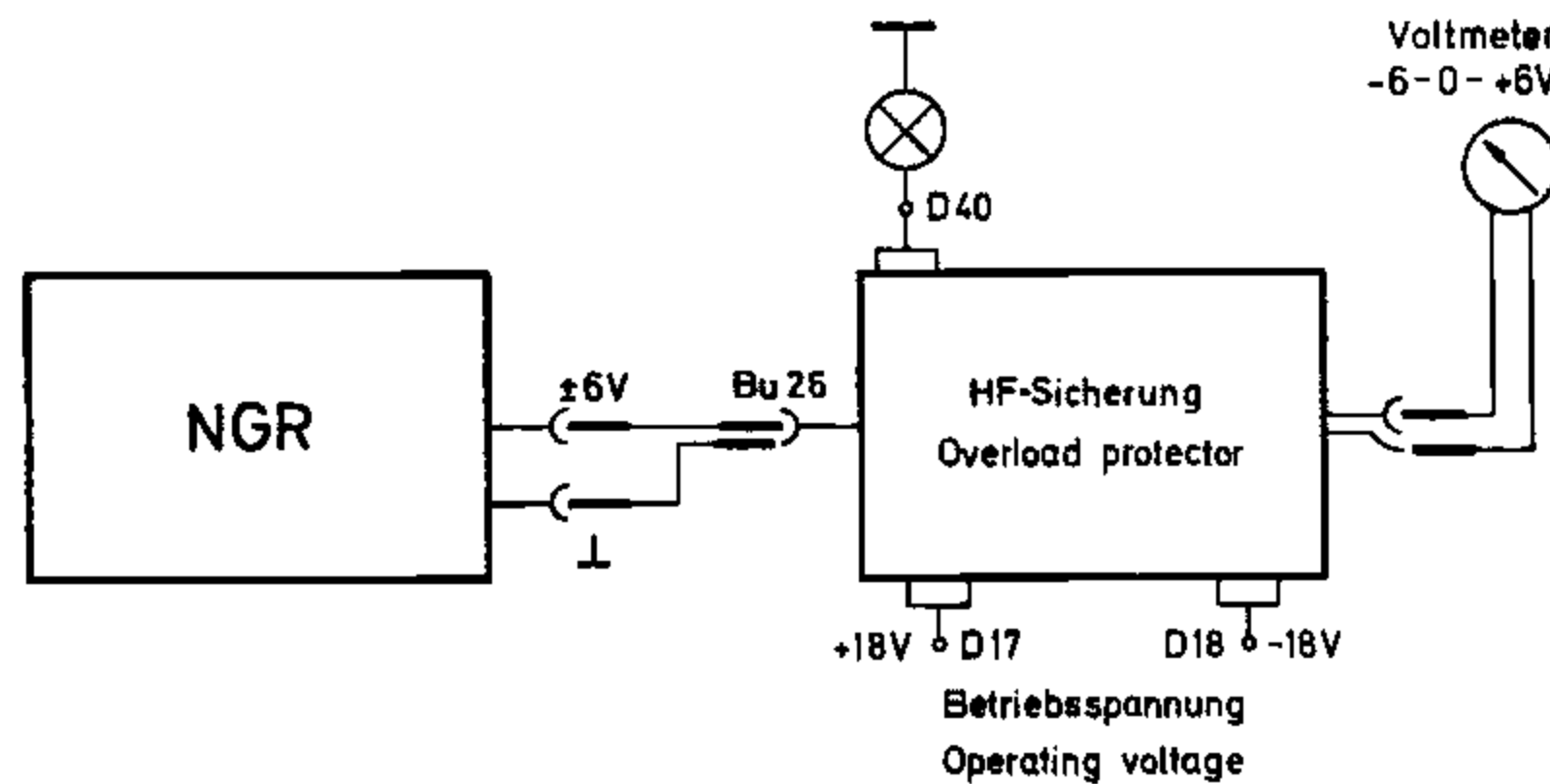

Fig. 5-10 Test setup for checking the threshold of the overload protector at DC

Measurement: Starting from 0 V , adjust the DC voltage to $+7\text{ V}$ and -7 V . The voltmeter reading must rise according to the adjusted DC voltage and drop back to 0 when the relay operates. The maximum voltage readings give the response thresholds: The positive response threshold must be at $+2$ to $+7$ and the negative response threshold at -2 to -7 V .

Adjust according to section 5.4.7.

Response threshold with AC voltage

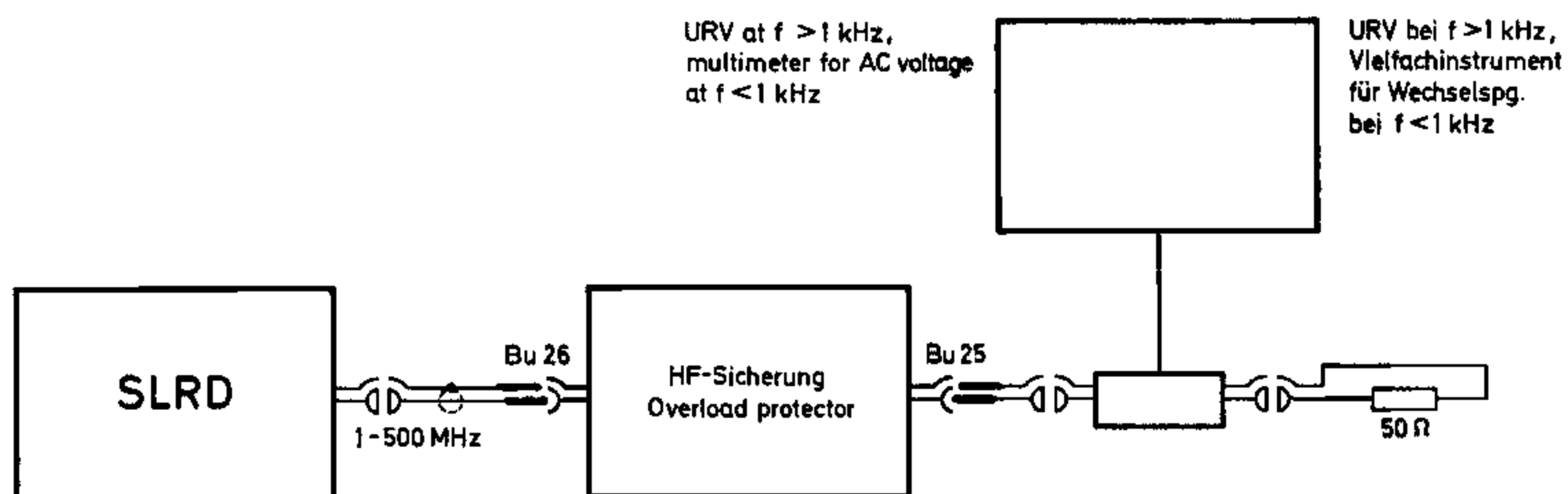

Fig. 5-11 Test setup for checking the threshold of the overload protector at AC

Measurement at test frequencies 10 MHz , 50 MHz and 490 MHz : Increase the signal-generator voltage starting from 0 . The voltmeter reading increases according to the adjusted voltage and drops back to 0 when the relay responds. The maximum voltage readings give the response thresholds.

Frequency	RF voltage
10 MHz 50 MHz 490 MHz	4.0 to 6.5 V

Table 8 Threshold of the overload protector

When the response threshold is exceeded (overload protector responds), the red lamp on the front panel must blink. In the transition region, the lamp lights. NOTE: The response threshold is affected by the length of the connecting cable.

5.3.14 Modulation Generator (in the Modulation Unit)

For the mechanical procedure to be followed when removing and checking the modulation unit, see section 4.19.2. Check the DC voltages according to circuit diagram 413141-6 S. Check the output voltage, output frequency, switch functions and distortion factor according to section 3.2.3.

5.3.15 Meter Amplifier (in the Modulation Unit)

For the mechanical procedure to be followed for removing and checking the modulation unit, see section 4.19.2. Check the DC voltages according to circuit diagram 413141 S. At full-scale deflection on the meter 5 an AC voltage of about 7.5 mV must be present at the input of the amplifier B1. Measure the AF level with the Millivoltmeter Type UVN ($Z_{in} \geq 100 \text{ k}\Omega$; $C_{in} < 50 \text{ pF}$). For checking the attenuator performance, set switch 3 to MOD. GEN. and vary knob 8 until an AF voltage of 1 V is present at R10 (contact 1 on S2). At the other attenuator resistors the following voltages must be measured: R11 \rightarrow 400 mV, R12 \rightarrow 100 mV, R13 \rightarrow 40 mV, R14 \rightarrow 10 mV.

Frequency response of indication: Feed $1 V_{rms}$ to input Bu3 AM EXT. from the RC Oscillator Type SRB covering the frequency range 10 Hz to 1 MHz. Adjust 11 so as to obtain a deflection of 80 % of the range of indication at $f = 1 \text{ kHz}$. With a constant input voltage, the meter reading may vary within the following limits (referred to the indication at $f = 1 \text{ kHz}$): 30 Hz to 20 kHz $< \pm 0.5$ scale division.

The adjustment is described in section 5.4.8.

5.3.16 Deviation Network

For the mechanical procedure to be followed for removing the deviation network, see section 4.19.9. The deviation network is checked within the signal generator. Check the DC voltage according to circuit diagram 41314 S Bl.1. A tolerance of $\pm 5 \%$ is permissible.

Checking with frequency modulation: For the test setup see Figs. 3-15 in section 3.2.3.5 and 3-16 in section 3.2.3.6 (measurement of frequency deviation). Adjust the frequency modulation for a deviation of 10 kHz at $f_{mod} = 1 \text{ kHz}$ (indication on the modulation unit). Check the FM deviation at a medium frequency of each range. The rated FM deviation is 10 kHz $\pm 0.65 \text{ kHz}$. Correct, if necessary, according to section 5.4.3.

Narrow-band sweeping: Check according to 3.2.6.

5.3.17 Connectors for the Frequenzkontroller

AC supply: Check the AC supply voltage at the socket for the Frequenzkontroller (Bu70, Bu71) at the rear of the signal generator. Voltage must be present if the power switch is depressed. Check the RF OUTPUT II for driving the Frequenzkontroller according to sections 3.2.4 and 3.2.6. Check the synchronization input according to section 5.4.2. Deviation with DC measured via synchronization input. Check the control leads at the multipoint connector Bu7 (at the rear) by means of a continuity tester according to the following table:

Range button depressed	Range (MHz)	Connections at Bu7 between contacts
I	0.4 - 48	H ↔ A and B ↔ F
II	47 - 74.7	H ↔ D and B ↔ F
III	74 - 129.5	H ↔ D and B ↔ L
IV	129 - 184.5	H ↔ E and B ↔ K
V	183.5 - 294.5	H ↔ E and B ↔ J
VI	293 - 404	H ↔ E and B ↔ N
VII	401 - 484	H ↔ E and B ↔ N

Table 9 Check the control leads at the multipoint connector Bu7

Contacts M and P are not wired.

Deviation measurement output see section 5.3.12.

5.4 Trimming Instructions

Procedures for trimming and the relevant criteria are described in this chapter. The required test setups are referred to in the performance check instructions for the individual subassemblies.

5.4.1 Power Supply

Measure the output voltages of +18 V and -18 V to chassis at the operating-voltage leads, using a voltmeter with an accuracy better than 0.5 %. Adjust with R662 (in 41314 S Bl.3) for $+18 \pm 0.1$ V, R682 (in 41314 S Bl.3) for -18 ± 0.1 V.

NOTE: Make the adjustment only if the frequency accuracy, deviation accuracy and output power do no longer conform to the specifications of section 1.3. When adjusting the operating voltages, check the frequency, deviation, output voltage and overload protection (see section 3.2.1).

5.4.2 Oscillator

The replacements for the oscillator are adjusted at the factory.

Current consumption: (Adjustment of operating points of transistors): Measure the current consumption of the oscillators according to section 5.3.2. Adjust for maximum RF amplitude at cable K1, using the associated potentiometers. The current consumption must be 2 to 7 mA. Turn the potentiometers counterclockwise until the current consumption referred to the maximum RF amplitude becomes less in ranges II to III by 20 %, in range IV by 10 %, in ranges V, VI and VII by 0.8 mA.

When the oscillator temperature rises to 60 °C, the RF amplitude must not be less than 30 mV (across cable K1, which is terminated with 50 Ω). If this value is not attained, the oscillator current must be increased. See "Output voltage" (penultimate paragraph in this section).

Adjustments

Range	Potentiometer
II	R 401
III	R 391
IV+I	R 381
V	R 371
VI	R 361
VII	R 411

Table 10 Adjustment of current consumption

Frequency range: Measure the frequency according to section 3.2.1.1. (It is possible to measure directly at the oscillator output with a sensitive frequency meter.) First make coarse frequency adjustments alternately at the highest and at the lowest frequency of the range.

NOTE: Prior to the adjustment, set the pointer to the centre of the scale window by means of the grub screw in the button (corresponds to the centre of the adjustment range; 60 mm ±0.5 mm from left or right border of scale window). The oscillator frequencies are given in the following table:

Range	Segment No.	Frequency Signal generator MHz		Frequency Oscillator MHz			Adjust with			Tolerance at		Permissible scale error over the range
		low	high	low	medium	high	low	medium	high	coarse adj. MHz	fine adj. $\frac{0}{n}$	
I ¹⁾	41313-2.8	0.4	48	129	152.8	176.6	—	—	—	—	—	80 kHz ± 1.2 %
II	41314-2.6	47	74.7	47		74.7	L 400		C 404	± 0.8	± 0.1	± 0.3 %
III	41313-2.7	74	129.5	74		129.5	L 390		C 394	± 1.0	± 0.1	± 0.3 %
IV	41313-2.8	129	184.5	129	152.8	184.5	C 388 ²⁾	L 380	C 384	± 1.0	± 20 kHz	to 177 MHz see range I; from 177 MHz ± 0.3 %
V	41314-2.9	183.5	294.5	183		294	L 370		C 374	± 2.0	± 1 %	± 0.3 %
VI	41314-2.10	293	404	293		404	L 360		C 364	± 3.0	± 0.1	± 0.3 %
VII	41314-2.11	401	484	401		484	C 418		C 414	± 3.0	± 0.1	± 0.3 %

Table 11 Adjustment of oscillator frequency

¹⁾ Range I is obtained by conversion of range IV (129 to 184.5 MHz) with a fixed crystal frequency.

²⁾ Turn C388 to stop and then continue adjustment with L380 at $f = 129$ MHz.

If the required scale accuracy is not attained in range I, the capacitance of C3813 must be increased in the case of negative errors and decreased for positive errors with due consideration of the temperature coefficient.

After the coarse frequency adjustment, adjust the frequency deviation as described below. Adjust the output voltage as described below under "Output voltage". Make the fine frequency adjustment; then check the frequency deviation again. Adjust alternately until all tolerances are kept to. Also observe the amplitude adjustment. Check the current consumption during the adjustment (see above). Check the sinewave form of the output voltage with a sampling oscilloscope. No distortion must be visible on the screen. If there is a distortion, reduce the current, taking into consideration the paragraphs "Current consumption" and "Output voltage" in this section.

Deviation (Constant deviation throughout the frequency range): Check for constant frequency deviation with a low-impedance voltage of $\pm 0.84 \text{ V} \pm 1 \%$ applied alternately to test point 1 (in circuit diagram 41314 S Bl.1). Adjust alternately at the highest, a medium and the lowest frequency of the range concerned.

Range		Adjust at frequencies (MHz)			Adjust with			Deviation (with DC)	Checking interval MHz
		low	medium	high	low	medium	high		
II	-2.6	47	50	74.7	C 409	R 459	C 401	40 kHz $\pm 1 \%$	1
III	-2.7	74	102	129.5	C 399	R 460	C 391		2
IV+I	-2.8	129	157	184.5	C 389	R 461	C 381		2
V	-2.9	183.5	238	294.5	C 379	R 462	C 371		4
VI	-2.10	293	348	404	C 361	R 463	C 369		4
VII	-2.11	401	442	484	C 411	R 464			3

Table 12 Adjustment of deviation

If the required frequency deviation cannot be obtained by means of the capacitors C409, C399, C389, C379, C401, C391, C381, C371, the capacitance of the parallel capacitors marked "Trimmwert" (factory-adjusted) can be increased or decreased (do not alter the temperature coefficient).

After having adjusted for constant deviation throughout the frequency range, check the frequency range and adjust, if necessary. If the frequency is readjusted, check again for constant deviation. Repeat the two adjustments alternately until a deviation of $40 \text{ kHz} \pm 1 \%$ is obtained at all points of adjustment. Also observe the amplitude adjustment of the output voltage as described below. Check the deviation with DC in intervals of 0.5, 1, 2 and 4 MHz, respectively in the whole frequency range (see table 8). A departure of $\pm 4 \%$ from the rated deviation of 40 kHz is permissible.

Deviation with DC measured via synchronization input (Deviation of the DC input): Alternately feed $+1.1 \text{ V}$ and -1.1 V with low impedance to socket Bu6. SYNCHRONISATION. The resulting frequency variation is the deviation which can be adjusted according to the following table:

Range	Frequency MHz	Adjust with	Deviation (with DC) kHz
I	41313 - 2.8	R 491	7.5
II	41314 - 2.6	R 492	60
III	41313 - 2.7	R 493	60
IV	41313 - 2.8	R 494	120
V	41314 - 2.9	R 495	120
VI	41314 - 2.10	R 496	125
VII	41314 - 2.11	R 497	125

Table 13 Adjust the frequency deviation

Output voltage: Measure the oscillator output voltage according to section 5.3.2. Adjust the output voltage according to the following table. Note that this adjustment influences the oscillator frequency and the deviation. Correct, if necessary. Check the oscillator for temperature stability, as described above under "Current consumption".

Range	Adjust with	Voltage mV _{rms}
I	—	—
II	C 407	50 to 80
III	C 397	50 to 80
IV	C 387	50 to 80
V	C 377	50 to 80
VI	C 367	50 to 70
VII	C 417	40 to 70

Table 14 Adjust the output voltage

If the voltage is higher than required, reduce the oscillator current. The RF voltage must be checked in the ranges II, III and IV at the reactance diodes. Measure with a probe voltmeter ($Z_{in} \geq 1 \text{ M}\Omega$; $C_{in} \leq 0.5 \text{ pF}$) directly at the reactance diodes. The maximum permissible voltage is $3.5 V_{rms}$; if necessary, reduce the oscillator current. Observe the output voltage.

Range	II	III	IV+I	V	VI	VII
Reactance diode	GI 400	GI 390	GI 380	GI 370	GI 360	GI 410

Table 15 RF voltage at the reactance diodes

At oscillator temperatures $\leq 60 \text{ }^\circ\text{C}$, the output voltage must not be less than 30 mV.

5.4.3 Frequency Modulation

For the test setup see Fig. 3-15.

Modulation setting: Set FM switch to INT. Set 8 switch for $f_{mod} = 1 \text{ kHz}$. Adjust potentiometer 18 so as to obtain a deviation of 10 kHz or 25 kHz or 50 kHz on the Frequency Deviation Meter Type FMV with the signal generator tuned to 200 MHz (reference frequency). Check the frequency deviation at the lower and the upper limit of all frequency ranges. Indication of deviation meter 10 kHz $\pm 3\%$ or 25 kHz $\pm 6\%$.

5.4.4 AGC Amplifier and Rectified-voltage compensator

For the test setup see Fig. 3-2 in section 3.2.1.2.

Prior to the adjustment, allow a warm-up period of 30 minutes. Ambient temperature should be $23 \text{ }^\circ\text{C}$. The instrument must be opened for the adjustment.

- Measure the RF output power at RF OUTPUT 16. Set the output attenuator 13 to -10 dB. Adjust the test frequency to 115 MHz. Using R273 (AGC amplifier 413114-3.10.7) adjust the output power to 0.5 mW.
- Using R276 adjust the voltage contact 6 of the AGC amplifier to 0 V $\pm 20 \text{ mV}$.

- c) Steps a) and b) being interdependent, repeat several times.
- d) Adjustment of rectified-voltage compensator 41314.17.3:
Set potentiometers R322, R325 and R327 mid-position. Connect VOR-ILS Unit. Adjust Signal Generator for a modulation depth of 40 % at 115 MHz.
- e) Using R327 adjust the AF voltage the at Bu14.1 to 990 mV \pm 1 mV.
- f) Using R325 adjust the rectified voltage at Bu14.1 to -3.500 V \pm 5 mV.
- g) Repeat adjustments e) and f) several times.
- h) Using R322 adjust the offset voltage at Bu14.1 to 0 V +30 mV at frequencies between 115 and 330 MHz.
- i) Check the voltages according to e), f) and h) and correct, if necessary.

5.4.5 Modulator

The measurement is made as described in section 5.3.8.

5.4.6 Crystal Stage

Test setup

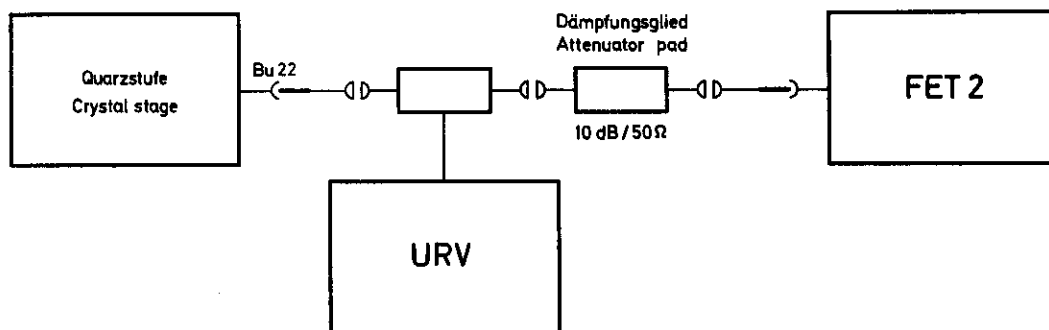

Fig. 5-12 Test setup for checking the crystal stage

Start of oscillations: Adjust C434 so that the oscillations are just initiated. Then advance C434 another 5° in the same direction (safety margin).

Spurious resonances: Turn the capacitor C431 through its range and observe the output frequency. No frequency jumps are allowed to occur. The output frequency must be 129 MHz \pm 7 kHz.

Output voltage: Adjust C431 for maximum output voltage, i. e. > 1.0 V into 50 Ω .

5.4.7 Overload Protector

Test setup: Feed a voltage of 5.5 V_{rms} (f = 60 MHz) to Bu26 of the overload protector or to the RF output Bu1 of the SMDA. Terminate Bu25 with 50 Ω via a voltmeter with insertion unit (see also section 5.3.13). Vary potentiometer R322 until relay Rs1 responds. Check according to section 5.3.13 at other frequencies and with DC.

5.4.8 Modulation Generator

For the **test setup** see Fig. 3-7 in section 3.2.2.1 and Fig. 3-8 in section 3.2.2.2.

Output voltage: The output voltage must be $> 1.0 \text{ V}$ into 200Ω (at Bu4) in all frequency ranges. For this purpose, the amplitude control **8** must be turned fully clockwise.

Frequency: Select the fixed frequency 300 Hz with R141. For this purpose, set switch **7** to position 0.3 kHz and knob **10** to position CAL. Adjust C3 so that the departure from the rated frequency is $\leq \pm 0.5 \%$ at all adjustable frequencies. Find a good compromise. Adjust the fine frequency tuning with R144 at 270 Hz (switch **7** at 0.3 kHz and knob **10** at -30 Hz).

5.4.9 Meter Amplifier

Output voltage indication of modulation generator

Test setup: Measure the output voltage of the modulation generator at output **20**. Setting of control knobs: Type-of-indication switch S12 to MOD. GEN. INDICATION switch to 100, switch **7** to 1 kHz.

Adjustment: Adjust the voltage at output **20** by means of R36 to obtain a reading of 100 scale divisions (full-scale deflection) on meter J2 with an output voltage of $1 \text{ V} \pm 2 \%$ at output **20**.

Check: Check the other ranges of indication according to the following table:

Voltage at 20 ¹⁾	Reading (J 2))
1 $V_{\text{rms}} \pm 2 \%$	100 divisions
0.4 $V_{\text{rms}} \pm 2 \%$	40 divisions
0.1 $V_{\text{rms}} \pm 2 \%$	100 divisions
0.04 $V_{\text{rms}} \pm 2 \%$	40 divisions
0.01 $V_{\text{rms}} \pm 2 \%$	100 divisions

Table 16 Check the ranges of indication

¹⁾ adjusted with the AMPLITUDE control **8**.

²⁾ corresponds to full-scale deflection.

Frequency-deviation indication: Check the indication of frequency deviation after the adjustment according to sections 5.4.2 and 5.4.3 have been made.

For the **test setup** see Fig. 3-15 in section 3.2.3.5. Feed a voltage of $1.6 V_{\text{rms}}$ ($f = 1 \text{ kHz}$) to the FM EXT. input Bu2 from an AF generator.

Setting of control knobs: Type-of-indication switch S12 to FM, INDICATION switch S13 to 10, FM switch S9 to EXT., deviation control **18** for 10 kHz (referring to frequency deviation meter).

Adjustment: Adjust potentiometer R35 for full-scale deflection on meter J2. Check the reading at 40 Hz, 300 Hz and 20 kHz. The maximum permissible departure is ± 0.5 scale division.

Indication of amplitude modulation

For the **test setup** see Fig. 3-10 in section 3.2.3.1.

Setting of control knobs: Select 60 MHz (range III) on the SMDA, and set type-of-indication switch S12 to AM, INDICATION switch S13 to 100, AM switch S8 to INT. Adjust AM control **11** for 70 % modulation (measured at the RF output).

Adjustment: Adjust potentiometer R37 for a meter reading of 70 % (corresponding to 70 % modulation).

Check: Check the indication at the signal-generator frequencies of 0.4 MHz and 400 MHz. The maximum permissible departure is 6.5 %.

5.4.10 Automatic IF Generation

For test setup see Fig. 3-1 in section 3.2.1.1.

Measurement: Feed a voltage of +14 V to the socket 7R on the rear wall of the signal generator via an 82-k Ω resistance. Vary the frequency of the SMDA at the beginning, in the middle and at the end of each frequency range switching the applied DC voltage on and off.

Adjustment: Adjust the frequency variation with R150 (413141-5 S) such that a mean value of 110 kHz \pm 12 kHz is obtained.

5.4.11 Mixer

Measure at RF output II (Bu5) with a selective voltmeter (e. g. Type ESU) tuned to the frequency of the crystal oscillator (129 MHz). Select frequency range I on the SMDA. (If the crystal oscillator is operating, the covers of the subassemblies must be closed.)

Adjustment: Adjust trimmer C89 for minimum crystal-oscillator voltage at the RF output.

5.5 Calibration of the Subassemblies

5.5.1 Oscillator: Zero Beat in Frequency Range I

Prior to calibration, adjust the oscillator according to section 5.4.2.

Calibration procedure: Turn the scale drum by 90° and affix to its left side a pointer for calibration marking. Adjust the pointer so as to keep the indicating error as small as possible over the entire range I (0.4 to 48 MHz). Then turn the scale clockwise ($f < 0.4$ MHz) until zero beat is indicated on meter 29 (see Fig. 5-5). Mark this point.

5.5.2 Attenuator

For checking the performance of the attenuator, it must be withdrawn from the signal generator (see section 4.19.4). Feed the test voltage into Bu22 and measure at Bu23. The circuit board 41314-3.10.7 must be inserted and connected up.

Checking the DC resistance

Test setup

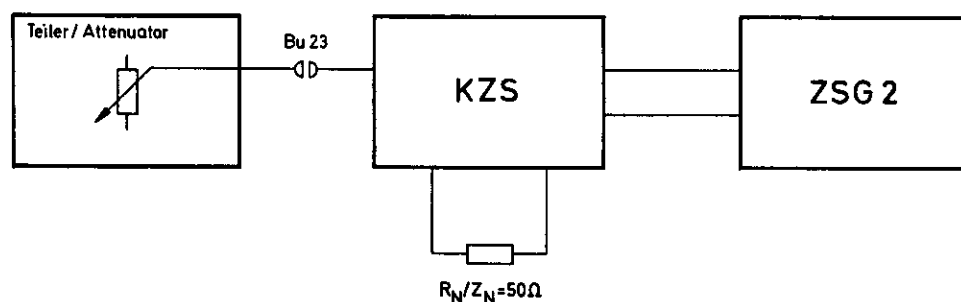

Fig. 5-13 Checking the DC resistance

Measurement: Turn the attenuator through its range. The resistance must be $50 \Omega \pm 10\%$.

Attenuator calibration

Test setup

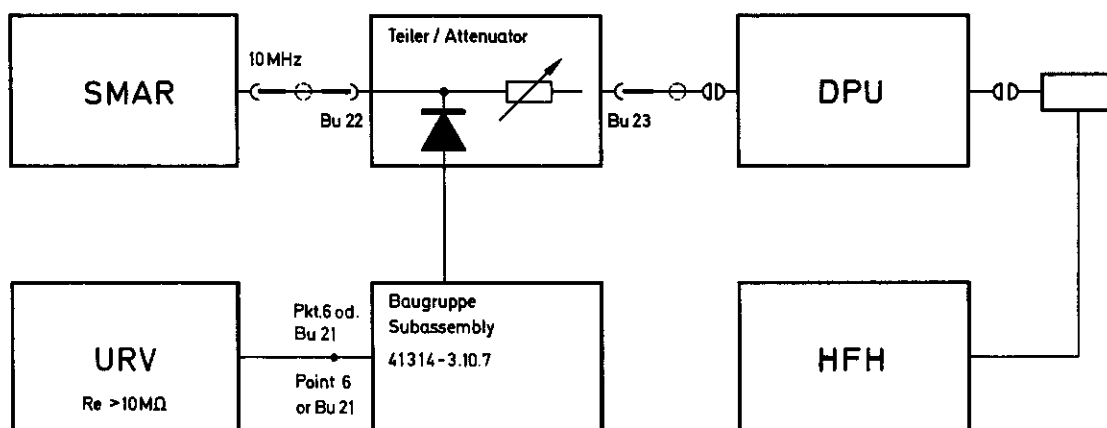

Fig. 5-14 Test setup for attenuator calibration

Attenuator performance: When turning the attenuator through its range the voltage indicated on the voltmeter must increase or decrease uniformly (no jumping).

Scale calibration: Efficient RF shielding must be ensured in order to measure also high attenuations. Solid-jacket cables are to be used for all connecting cables. Connect the calibrated attenuator Type DPU with cable K9 and an adapter to the attenuator. Keep the line between the generator Type SMAR and the attenuator as short as possible. Tighten down the plug-and-socket connections. The input voltage can be observed on the DC voltmeter type URV on the VOR-ILS unit. It is advisable to use a stabilizer for the generator, receiver and voltmeter. Release the attenuator lock.

Calibration procedure: The calibration frequency is 10 MHz. Do not apply any voltage to socket Bu22. Vary the potentiometer R273 on 41314-3.10.7 until -3.5 V are measured at the VOR-ILS output. Move the attenuator carriage to the right stop (minimum attenuation), set the calibrated attenuator for maximum attenuation, i. e. 120 dB and increase the voltage on the SMDA ($1.5 V_{\text{rms}}$, max.) until the meter on the receiver gives full-scale deflection. The rectified voltage of -3.5 V at the VOR-ILS unit must be kept constant during all further steps of the calibration procedure by means of the generator voltage.

Residual attenuation and 1- V_{EMF} marker: Reduce the attenuation of the calibrated attenuator by $3 \pm 0.1 \text{ dB}$ and increase the generator voltage and the attenuation of the attenuator until the rectified voltage at the DC voltmeter and the receiver voltage have reached again the old value (-3.5 V). Mark down "1 V". Reduce the attenuation of the calibrated attenuator by another 7 dB, adjust the generator voltage to a constant rectified value and the attenuator such that full-scale deflection is obtained on the receiver. The dBV scale is calibrated every 2 dB down to -80 dBV . The attenuations of the attenuator and the calibrated attenuator must be varied in opposite directions. Keep the rectified voltage constant with the aid of the generator.

From -20 dBV onwards the spacings between the division lines must be absolutely equal. From -80 dBV onwards the spacings should be checked. If they are wider or smaller extrapolate the scale linearly starting at least from -100 dBV . Draw the scale accordingly and check it after insertion.

Attenuator locking position: After the scale has been inserted and checked set the attenuator approximately 0.2 mm beyond 1 V_{EMF}. In this position, the attenuator is locked. Insert the completed scale in the attenuator and check the attenuator.

The voltmeter indication (test receiver indication) may fluctuate by $< \pm 0.6$ dB over the entire frequency and attenuation range.

Meter diode

Test setup

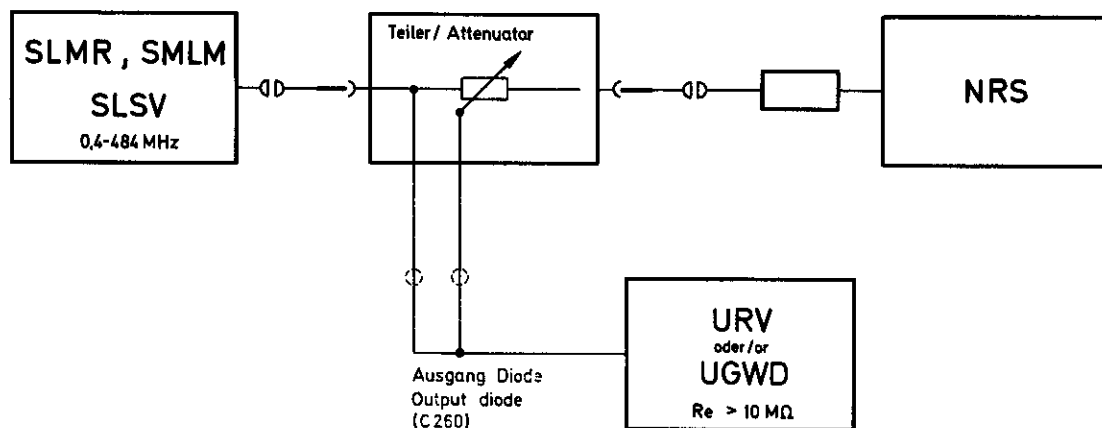

Fig. 5-15 Test setup for checking the meter diode

With a constant RF voltage at the attenuator vary the frequency in the range from 0.4 to 490 MHz. Measure the DC voltage at the diode output to chassis with a supply voltage of 0.7 V (= EMF 1.4 V). It must be $0.7 \text{ V} \pm 5\%$. The DC voltage (rectified voltage) must not change by more than 2% over the entire frequency range.

5.5.3 Calibrating the Fine Tuning of the Modulation Frequency

For the **test setup** see Fig. 3-7 in section 3.2.2.1.

Prior to calibrating the fine tuning, the modulation generator must be adjusted according to section 5.4.8.

Calibration procedure: Set switch **8** to position 0.3 kHz. Turn knob **10** fully counterclockwise and adjust the marking CAL. to the reading marker on the front panel. (Frequency indication on the counter: 300 Hz). Turn knob **10** clockwise away from the locked position. The generator frequency must now be 267 to 270 Hz (adjust with R144). Turn the knob clockwise until the frequency just begins to change. Mark this point - 30 Hz. Then adjust the following frequencies with knob **10** in the listed order and mark accordingly.

Modulation frequency Hz	Fine tuning Hz
300	0
350	+ 50
400	+100
450	+150
500	+200
550	+250
600	+300
650	+350
700	+400

Table 17 Calibration the fine tuning of the modulation frequency

The marking is made with pencil directly on the edge of the knob. The markers and the marking arrow on the front panel should form on line.

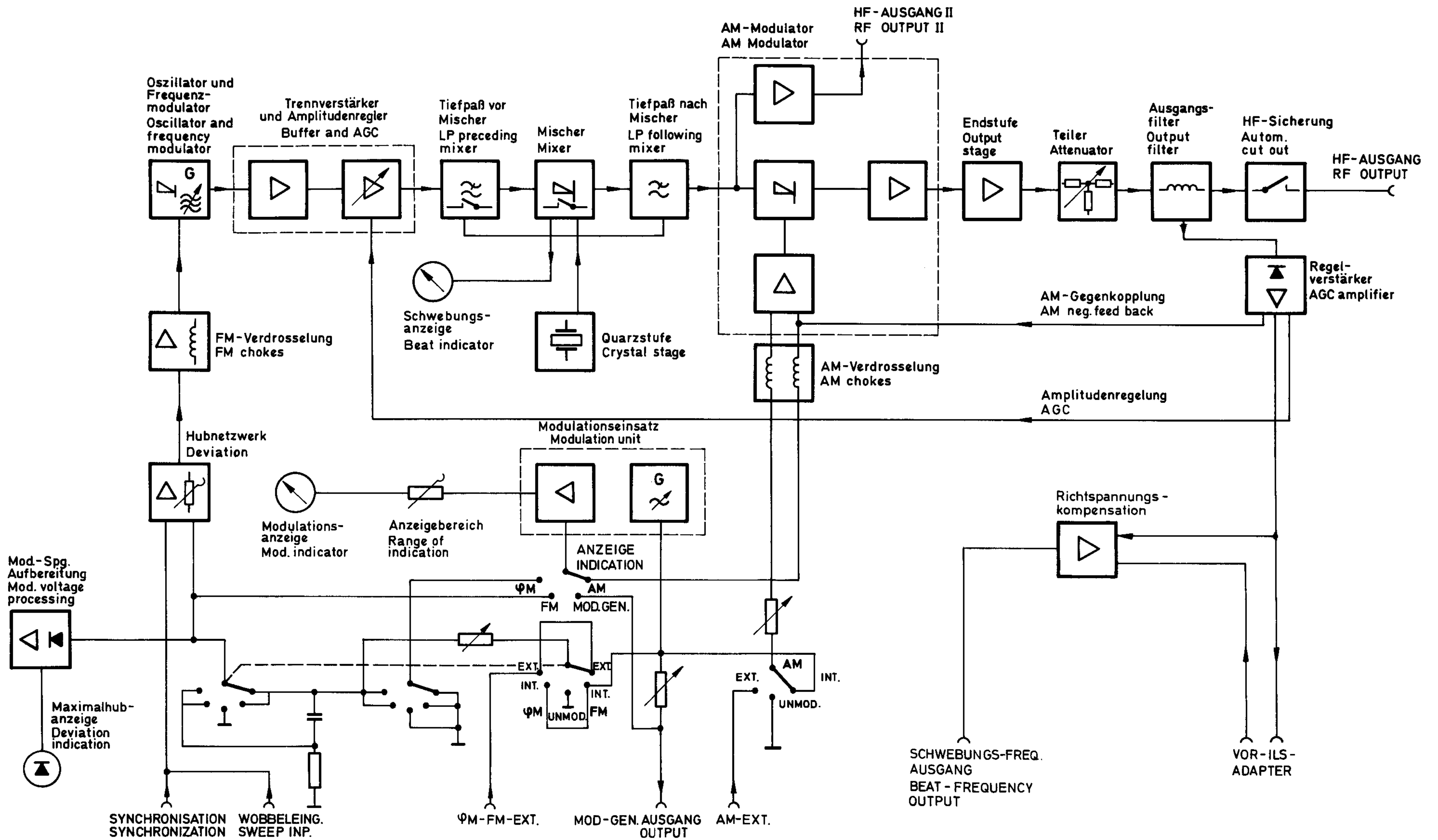

Blockschaltbild Bild 1-2
Block diagram Fig.1-2



Bild 2-1 Bedienungsbild 1
 Fig. 2-1 Front panel



Bild 2-2 Bedienungsbild 2
 Fig. 2-2 Rear panel

Bild 2-1 Bild 2-2
 Fig. 2-1 Fig. 2-2

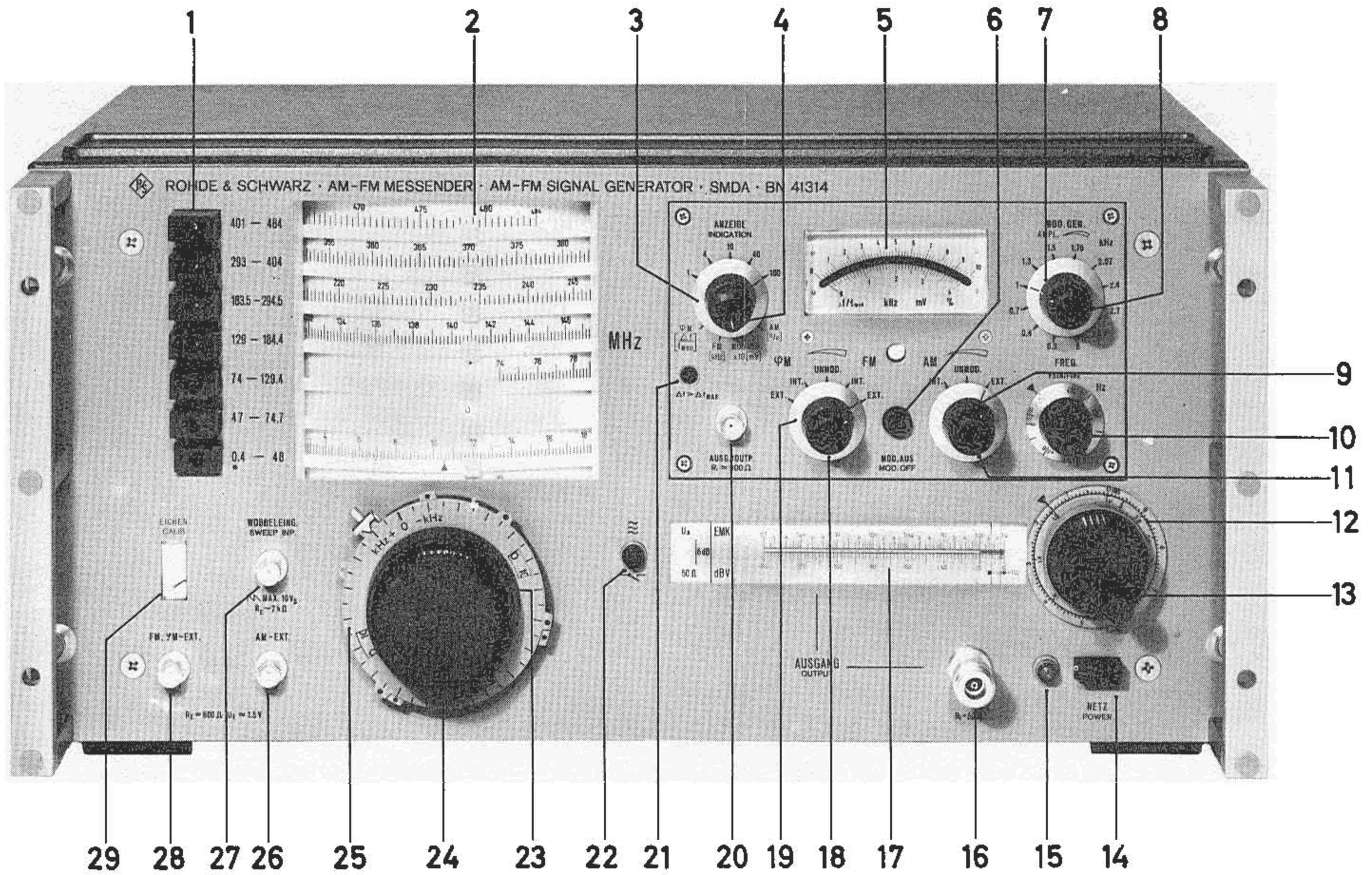

Ansicht von unten ohne Deckel
 Bottom view, cabinet removed

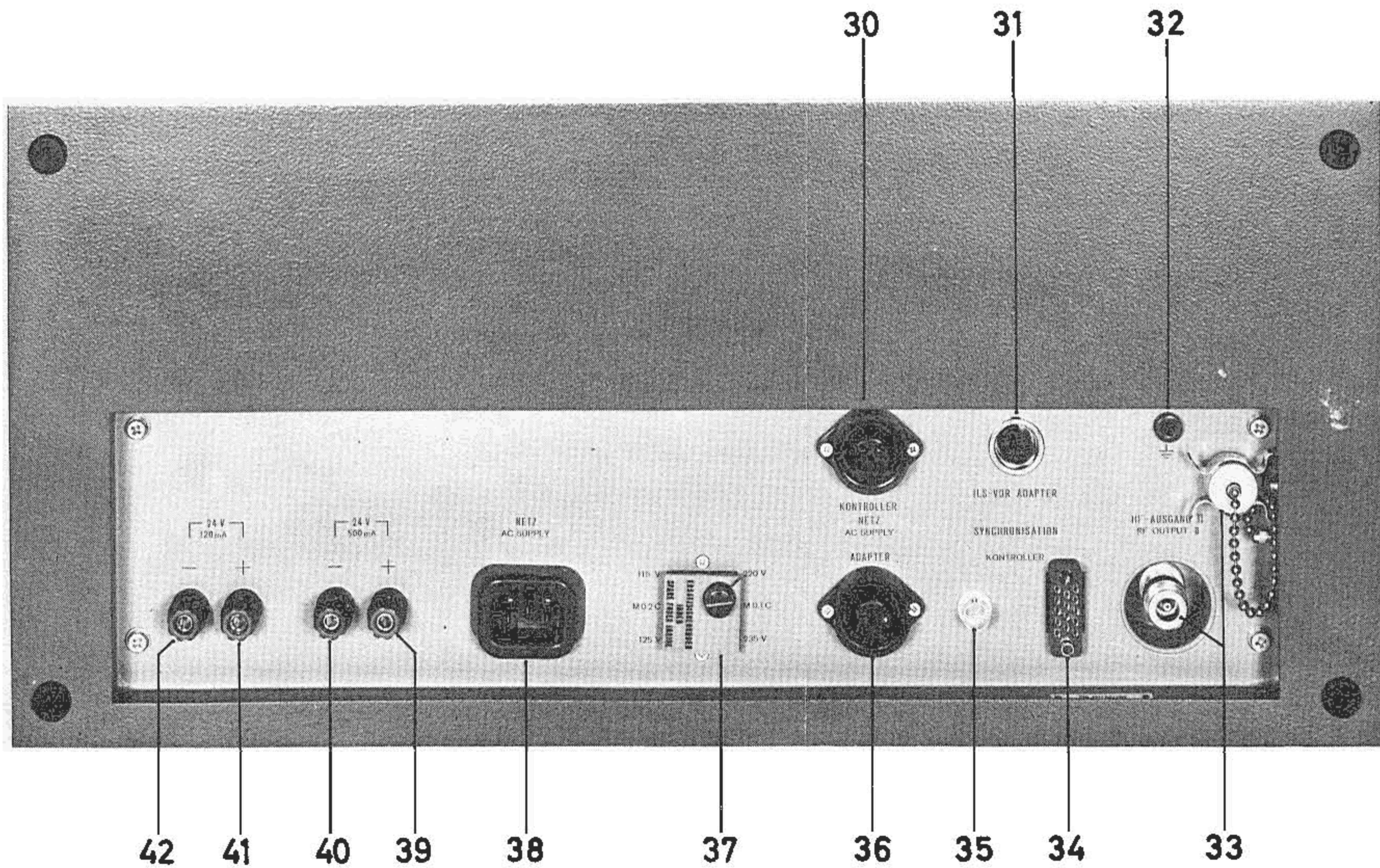
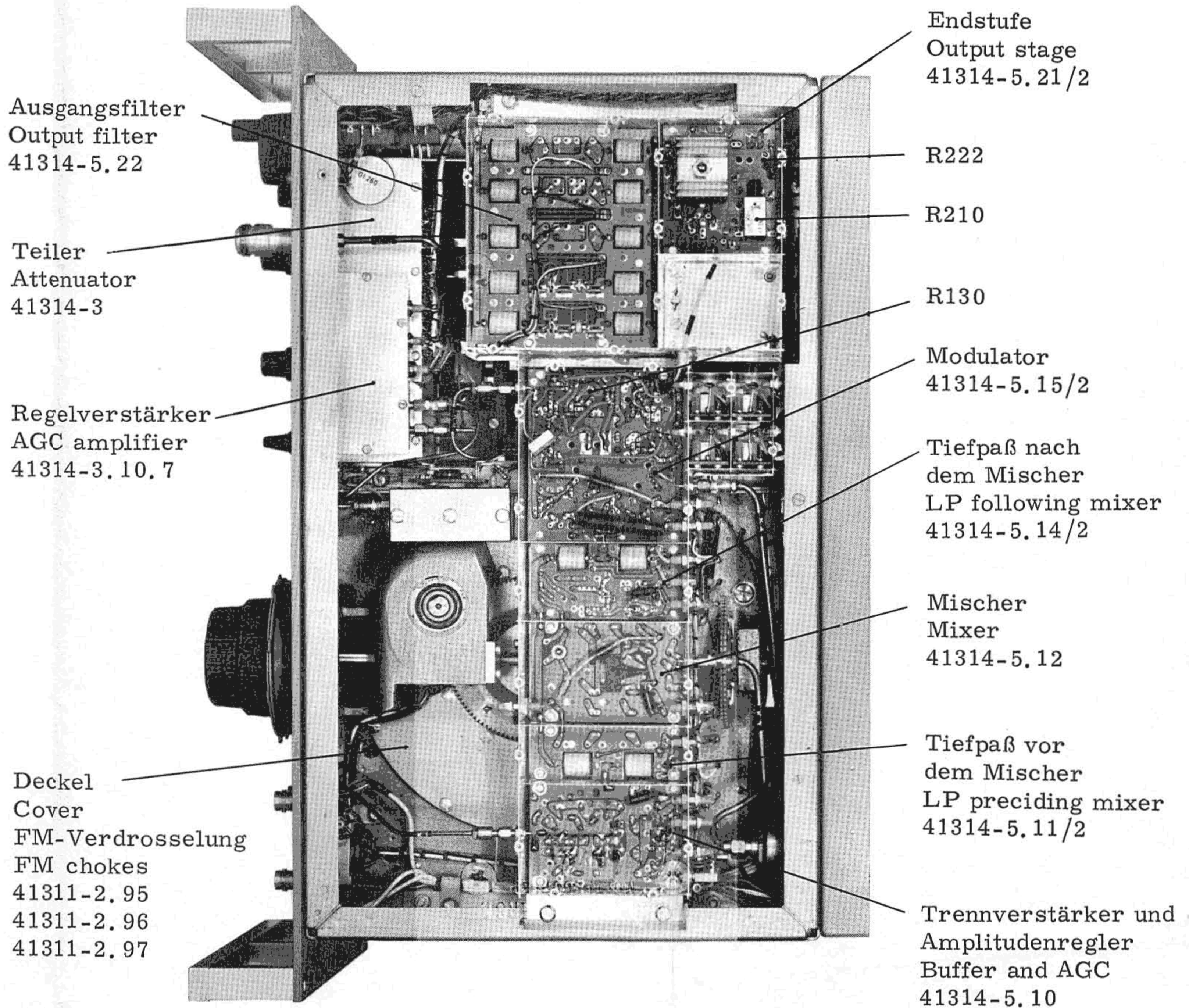
Bild 4-1

Fig. 4-1

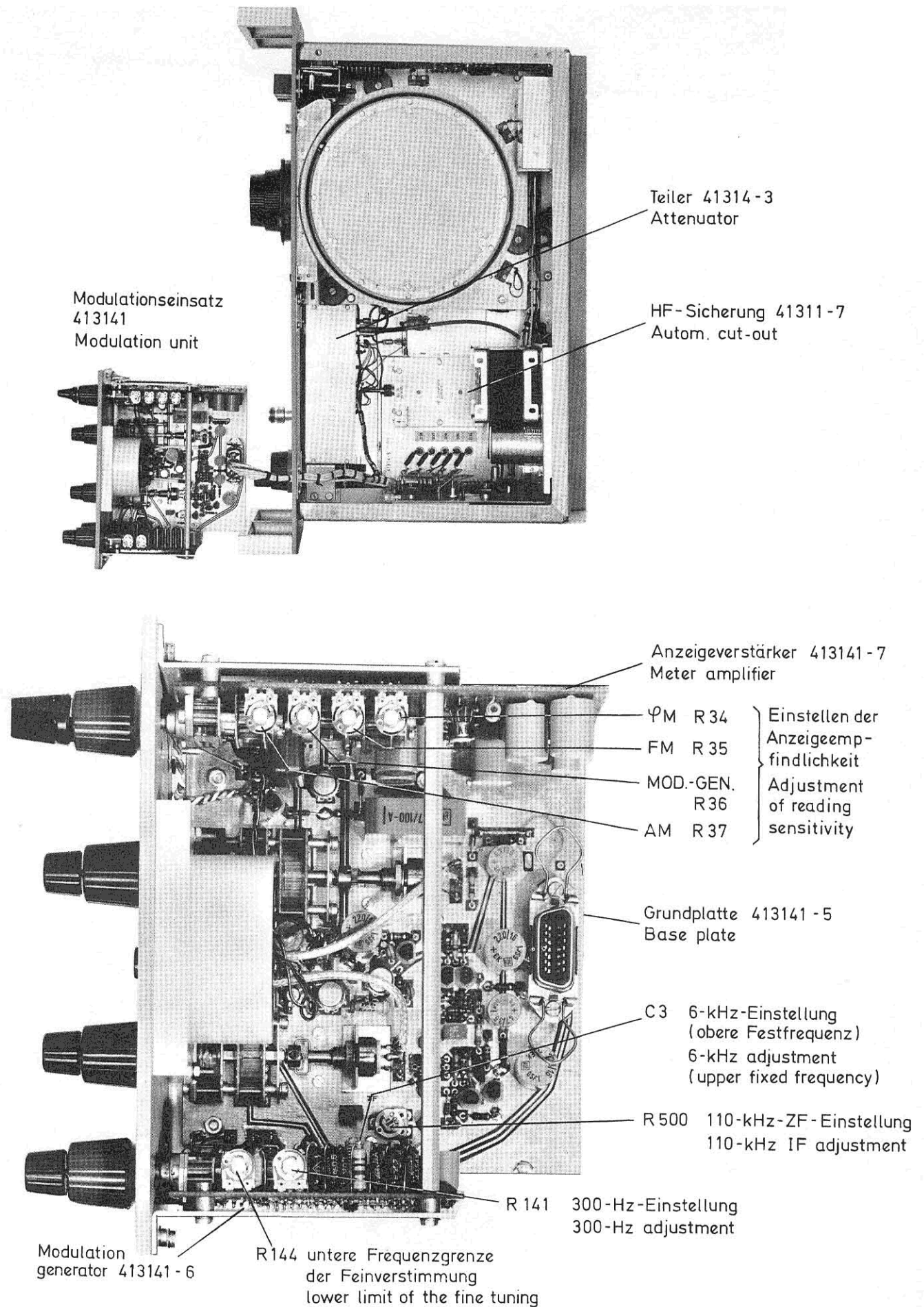

Ansicht von oben mit herausgezogenem Modulationseinsatz
Top view, modulation generator with drawn

Bild 4-2
Fig. 4-2



Bild 4-3 Ansicht von oben ohne Kasten
Fig. 4-3 Top view, cabinet removed

Transformatorplatte
Transformer
41311-4.5

Sicherungskasten und
Netzspannungswähler
Fuse box and topping panel

Quarzstufe
Crystal stage
41313-9

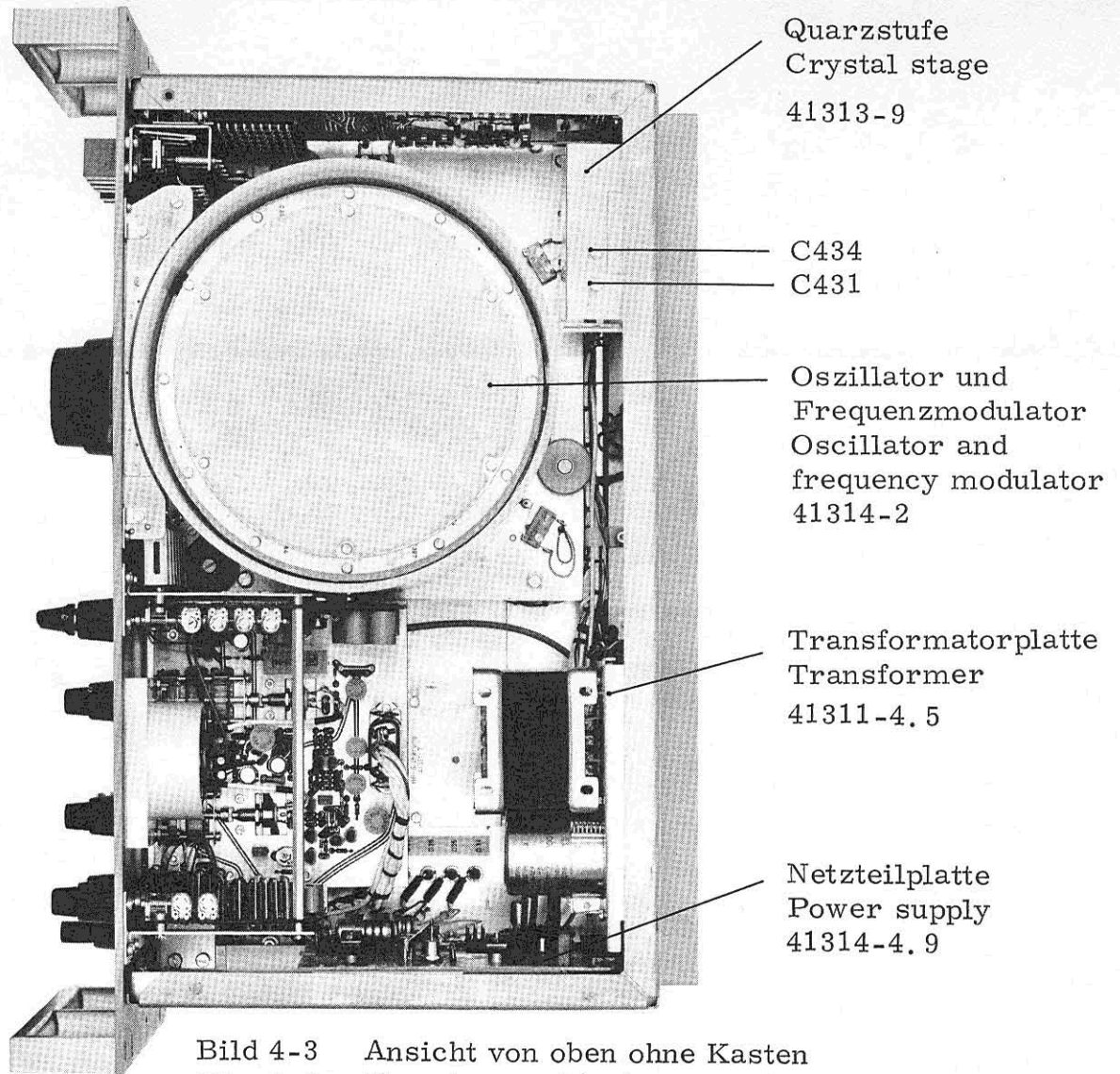

Bild 4-4 Ansicht von hinten ohne Kasten
Fig. 4-4 Rear view, cabinet removed

Bild 4-3
Fig. 4-3

Bild 4-4
Fig. 4-4

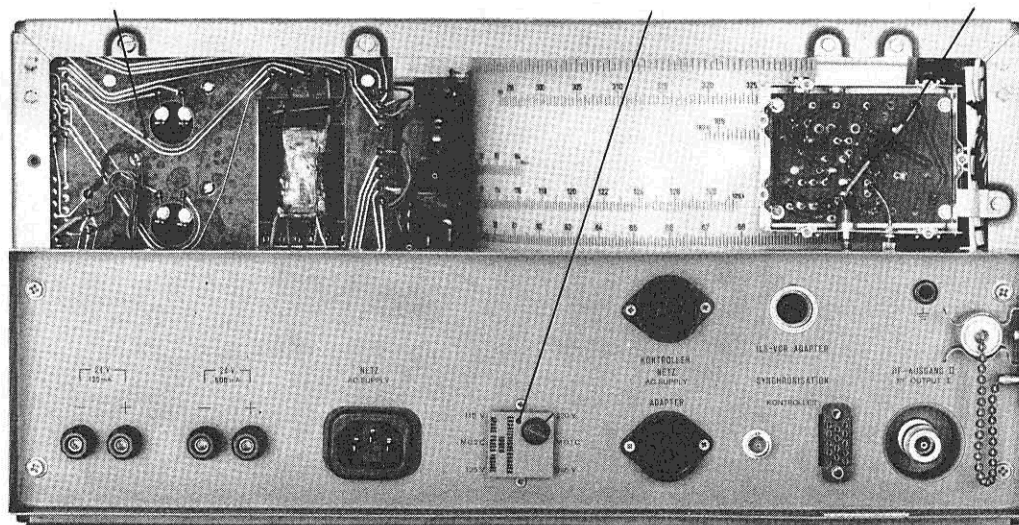

Bild 4-5 Ansicht von der linken Seite ohne Kasten
Fig. 4-5 Left-hand side view, cabinet removed



Bild 4-6 Ansicht von der rechten Seite ohne Kasten
Fig. 4-6 Right-hand side view, cabinet removed

Bild 4-5
Fig. 4-5

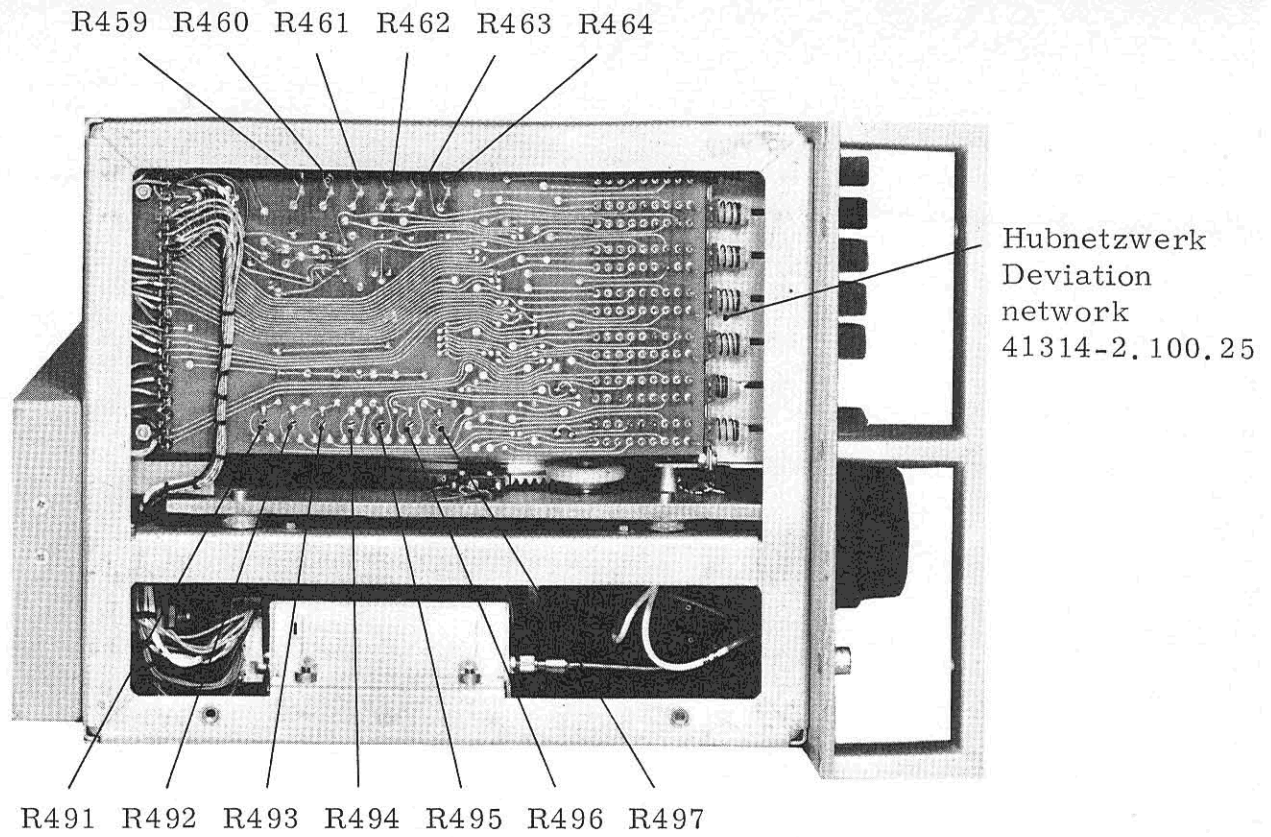
Bild 4-6
Fig. 4-6

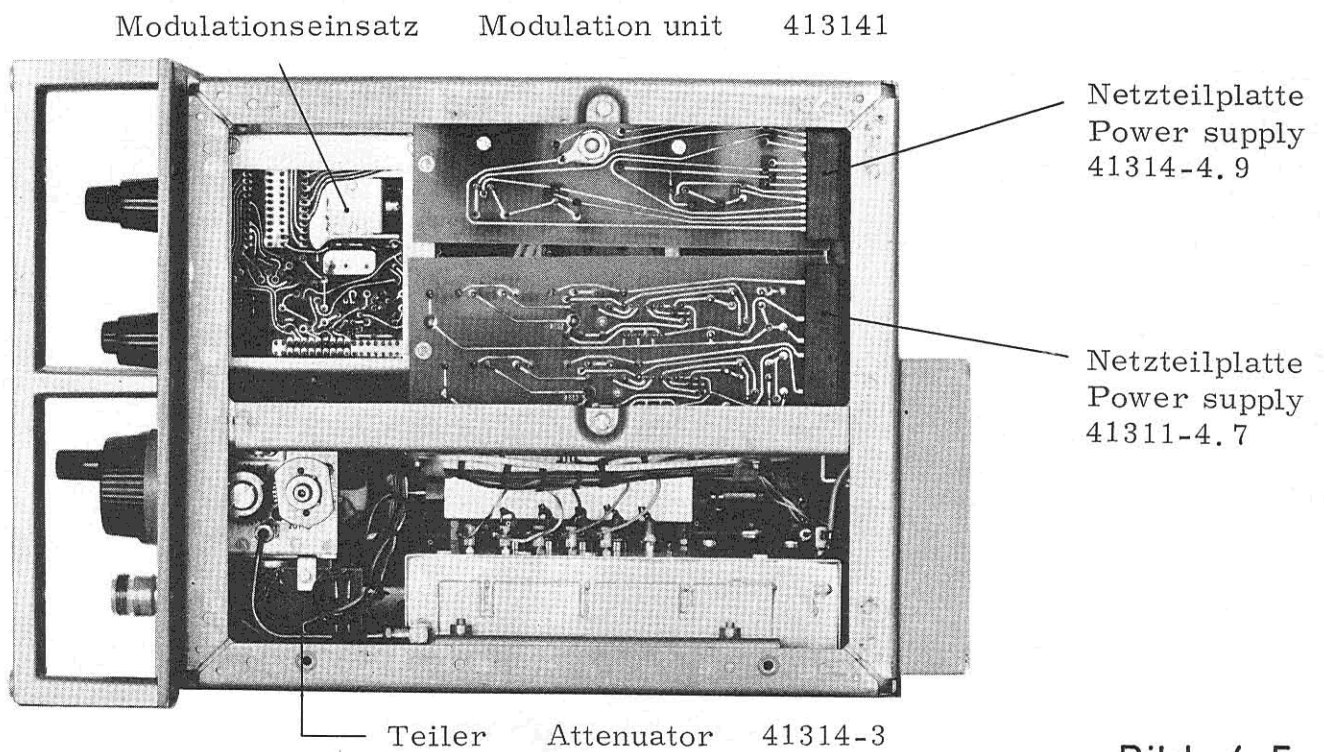
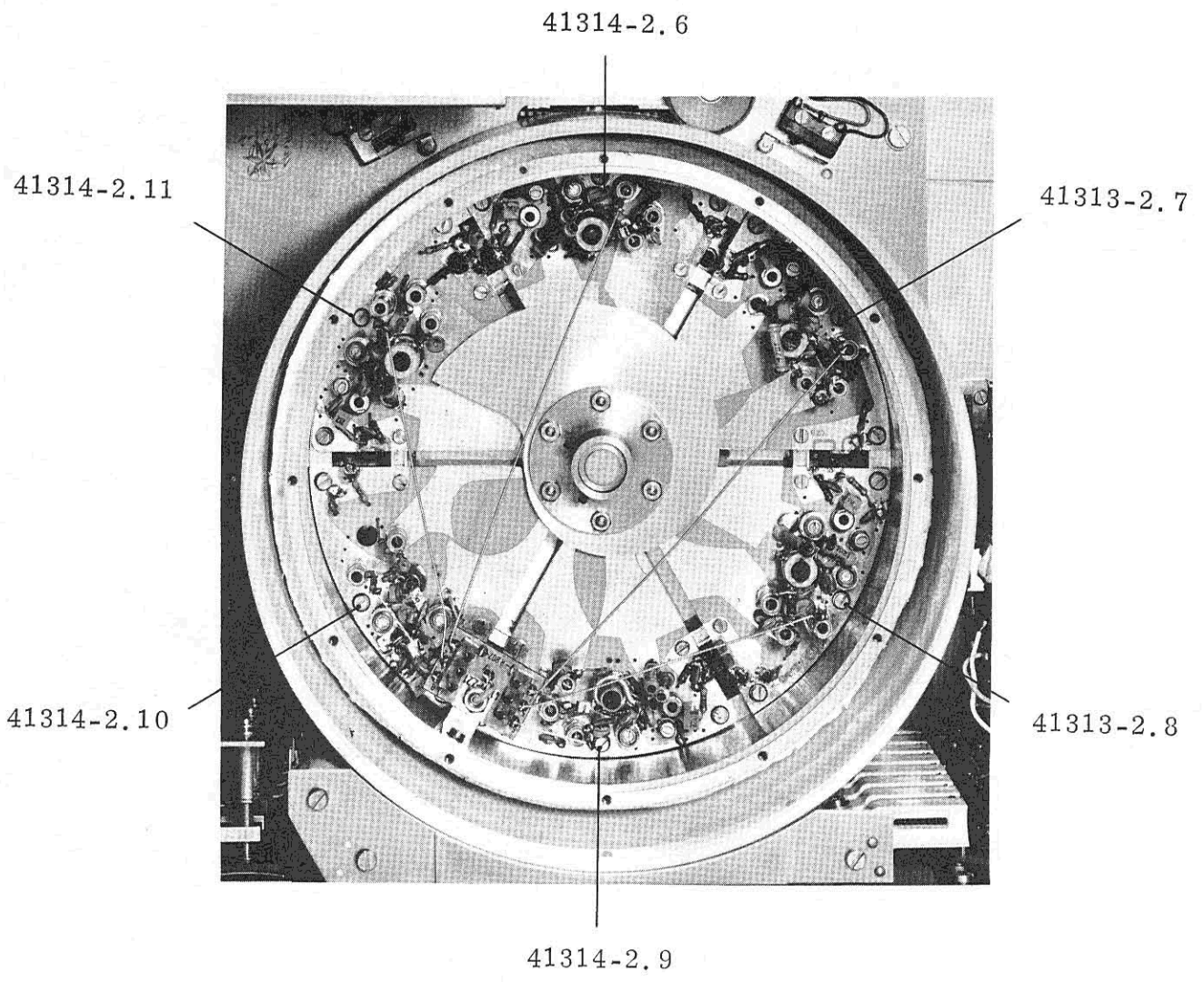

Oszillator
Oscillator

Bild 4-7
Fig. 4-7

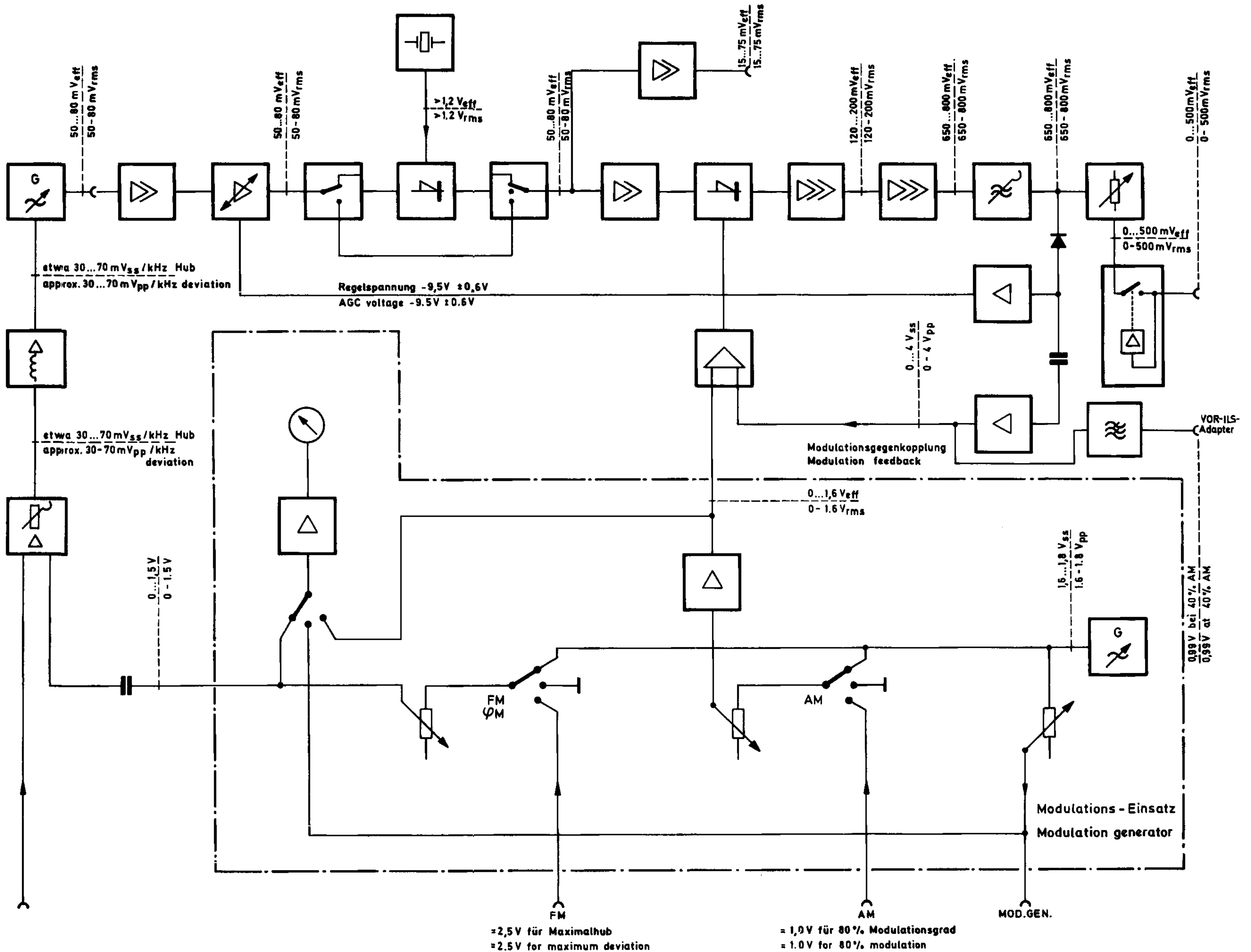

Pegelplan Bild 5-16
 Level diagram Fig. 5-16